

REA and XBRL GL: Synergies for the 21st Century Business Reporting System

Denise G. Amrhein. Saint Louis University. USA. amrheidm@slu.edu

Stephanie Farewell. University of Arkansas-Little Rock. USA. smfarewell@ualr.edu

Robert Pinsker. Old Dominion University. USA. rpinsker@odu.edu

Abstract: incorporating an instance document example, we suggest a framework linking the Resource-Event-Agent (REA) model and eXtensible Business Reporting Language Global Ledger (XBRL GL) as a way to extend the generalized XBRL GL taxonomy. Using the REA semantic model to extend the existing XBRL GL taxonomy provides an ontology and associated process that is reusable. The resulting framework can provide uniform access to information and more reporting and query permutations, thereby facilitating more comprehensive and timely business reporting.

Key words: XBRL, XBRL GL, XML, REA, Business Reporting, Accounting Information Systems

1. INTRODUCTION

Traditional business reporting systems lack the semantics and present too narrow of an accounting “view” to provide dynamic, real-time data that can span business processes. In many instances, the business reporting system is incompatible with other

functional information systems within an organization, as well as with the systems of supply chain partners and other information stakeholders (i.e., banks, governmental organizations, investors). Thus, significant and costly inefficiencies arise when business event data stored in various systems has to be collected and assembled to provide the desired communication.

REA was originally developed to provide a generalized framework for an accounting information system (AIS) in a database environment (McCarthy 1982). The REA semantic model represents a business as a collection of related economic resources, economic events, and economic agents. Conceptually, a REA-based system can capture a comprehensive set of business information more efficiently than traditional business reporting systems, allowing organizations to make more efficient and better informed business decisions. However, REA needs a technological language to help take advantage of its benefits. Such a tool must support adaptability to address business changes, uniformity to reduce the complexity, and efficient performance to address time constraints (Nakamura and Johnson 1998). EXtensible Business Reporting Language Global Ledger (XBRL GL), with the inherent characteristics of extensibility and interoperability meets these criteria. XBRL GL is the language that REA needs to allow users to gain strategic advantage through the use of financial and non-financial information. In essence, REA provides the model to determine what information should be captured, how to capture it, and how to tie the information together, and XBRL provides the means to communicate, link, and share that information among disparate systems.

Our paper is designed in the spirit of Geerts and McCarthy (1997) as a conceptual description of REA, XBRL, and a business reporting system incorporating both. We address the need for further work examining the integration of REA with an XML architecture, as outlined by Geerts (2004), by proposing a system that leverages the strengths of REA, a semantic model for capturing information about economic phenomena and XBRL, a metadata representational language for communicating business and financial information.

First, we present the comprehensive REA model and its benefits focusing on ontological contributions. We discuss specifics related to XBRL GL next. This is followed by a section describing how the two concepts can be combined to take advantage of their synergies. From the perspective of “design science,” we then provide an artifact of a documented process for integrating the two concepts by using REA to

guide an XBRL GL taxonomy extension and the creation of an instance document (Simon 1996; Hevner *et al.* 2004).

2. BACKGROUND

REA as a Business Process Semantic Model

The REA model was originally developed to provide a generalized framework for an Accounting Information System in a database environment (McCarthy 1982). Further, REA modeling has been discussed as a method for organizational information systems to capture all business processes and events including “any strategically significant business activity management wants to plan, control, and/or evaluate” (Denna *et al.* 1998, 365). Conceptually, a REA-based system can capture a rich set of business information more efficiently than traditional business reporting systems.

REA’s comprehensiveness moves it beyond merely capturing and reporting on business transactions (economic events) to capturing and reporting on other non-transactional business events, including information such as “commitments” and “typification.” A commitment is an “agreement to execute an economic event in a well-defined future that will result in either an increase of resources or a decrease of resources” (Ijiri 1975, 130). Typification, which can be related to resources, events or agents, is a conceptual abstraction that defines the identifying characteristics or essence of a concrete set of objects (i.e., an event type could be a raw materials purchase). It focuses on the recurring components of business events and shares the object-oriented adage of reuse. Specifically, the typified event, agent, and resource can be reused with other economic exchanges, rather than being limited to one form of economic exchange. Typification allows for increased internal controls through validation checks.

The comprehensive REA model can be divided into a policy infrastructure and an accountability infrastructure.¹ The policy infrastructure is where the relationships among the resource types, event types, and agent types of an organization are modeled, defined and linked to the corresponding REA process type and task types; this creates an invariant structure. The accountability infrastructure involves instantiation, where the actual transaction and business event data occurs and is captured. Connecting the policy

¹ “Comprehensive” refers to the inclusion of the commitment and typification concepts introduced after McCarthy’s (1982) “basic” REA model.

infrastructure to the accountability infrastructure within the system design facilitates systems integration. In turn, systems integration leads to more rapid feedback and data analysis. A connected policy infrastructure and accountability infrastructure allows for a potentially more efficient, integrated and directed planning and control cycle than would typically be seen with a traditional transactions-based model, which typically lacks the linkage between infrastructures. The comprehensive REA model from Geerts and McCarthy (2002) is depicted in Figure 1.

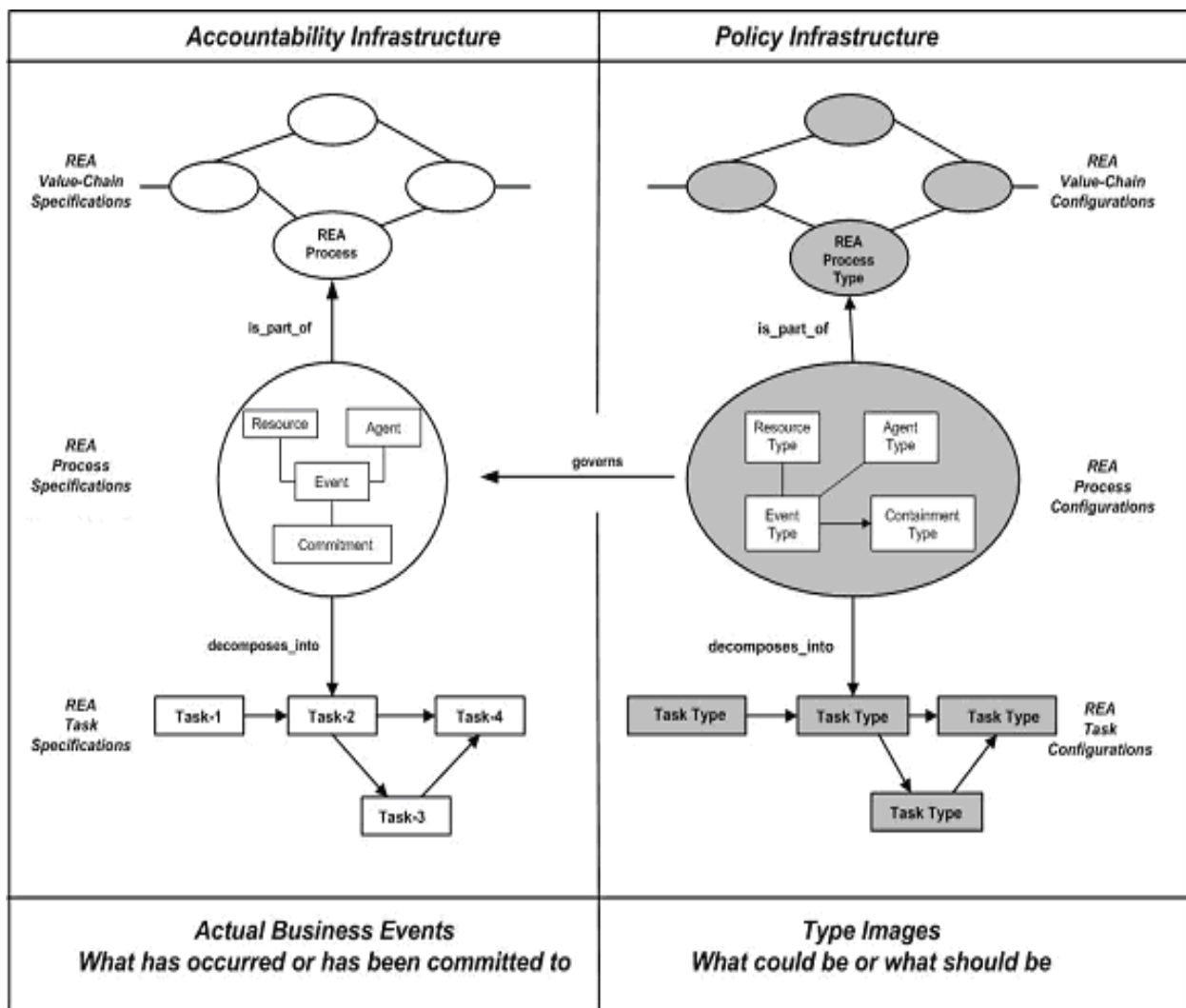

Figure 1 The REA Levels and Type Images. Geerts and McCarthy 2002

The policy infrastructure depicted in Figure 1 shows how data collection and reporting should occur in the organization by configuring (identifying and grouping) the appropriate resource type, event type, agent type, and commitment type for a given REA process type. Figure 1 also depicts how the REA process level can be decomposed down to the task type. The accountability infrastructure in Figure 1 shows what has occurred or been committed to by specifying the actual resources, events, agents and commitments involved in a given REA process. In addition, Figure 1 illustrates how the REA process configurations from the policy infrastructure govern the REA process specifications of the accountability infrastructure by specifying the appropriate types of resources, events, agents, and commitments that may be included in a given REA process. Tying the policy infrastructure to the accountability infrastructure allows the organization to confirm that the resources, events, and agents involved at the accountability infrastructure level (e.g., the instantiations) are of the appropriate type and that the economic commitment has been fulfilled. A comprehensive, REA-designed information system would emphasize the impact of recording all the essential characteristics of business events.

The policy-accountability infrastructures' linkage can have important implications for strategic decision-making. For example, a promise to purchase is a commitment that would not be captured and reported by a traditional business reporting system because it does not meet the accounting definition of a "transaction" (involving changes in balance sheet or income statement accounts). However, this promise to purchase would be captured and reported under the comprehensive REA model. Capturing this information is significant, because the level of commitments relating to future transactions could influence strategic decisions such as those related to capacity utilization issues and the need for expansion or retrenchment.

REA advocates capturing data at the element level. Its usage permits knowledge sharing and promotes efficiencies that traditional business reporting systems lack (Geerts and McCarthy 2000). Since REA is object driven, as opposed to artifact driven, it is only necessary to enter information into the system once in order for it to be reused repeatedly by various information stakeholders.² Interoperability allows for enabling communication between different systems (internal or external to the organization). In summary, a REA-based business reporting system could provide organizations with competitive advantages through integration, reusability, and interoperability.

² This reuse process is referred to as conclusion materialization. For example, it is not necessary to maintain information about the balance of accounts receivable, because it can be determined from the difference between the amount of sales and the amount of cash receipts.

XBRL GL

While the focus of XBRL has traditionally been external financial reporting, there are significant benefits to be derived from its use in internal reporting. XBRL GL is designed to facilitate the efficient processing and sharing of financial and non-financial information within a business (xbrl.org/GLTaxonomy). It consists of modules that allow “the representation of anything that is found in a chart of accounts, journal entries or historical transactions, financial and non-financial. It does not require a standardised chart of accounts to gather information, but it can be used to tie legacy charts of accounts and accounting detail to a standardised chart of accounts to improve communications within a business” (xbrl.org/GLTaxonomy).³ XBRL GL facilitates the flow of information through the system including the consolidation process (from subsidiaries to holding company or parent) and rolls-up into both internal and external reporting. Figure 2 illustrates not only the ability of XBRL GL to combine information from disparate systems, but also the roll-up of XBRL GL into XBRL Financial Reporting (XBRL FR). In addition, the instance document may reside in a virtual XBRL holding system.

May 17, 2006. “XBRL GL, the standardized Global Ledger, is a standard format to represent financial and non-financial data at the detail level, move the data between different systems and applications, and provide context for drilling down from summary reporting (XBRL FR) to the detail data that flows to it,” (Garbellotto 2006, 59). It is not intended to take the place of an ERP system. XBRL GL allows users to tag the items in the data warehouse so that they can be used, reused, and combined with data from other sources. XBRL GL will “help make even the most integrated system more interoperable, and data more reusable, in a cost-effective way” (Garbellotto 2006, 60). Appendix A provides an annotated explanation of a portion of an inventory purchase instance document using the XBRL GL taxonomy. We will be referring to it next, as well as later in the paper when we discuss more detailed examples.

Figure 3 is a segment of the purchase order instance document contained in Appendix A. The GL taxonomy contains elements to capture information such as who entered the purchase order, when the purchase order was entered, the terms, whether the purchase order is chargeable or reimbursable, and the date received. Thus, non-financial information can be captured in addition to the financial facts. While on the surface the

³ The modular taxonomies that comprise XBRL GL are: Core, Advanced Business Concepts, MultiCurrency, concepts for Saxonian jurisdictions and the tax audit file. While the use of all modules is not required, it is helpful to view each module as part of the whole.

XBRL GL taxonomy may appear to consist of entirely traditional financial artifacts (e.g., debits, credits, and accounts), it contains other elements as well. For example, information about the company reporting the transactions would not typically be captured by the reporting system (figure 3, line 30). By embedding the company name into the instance document, it continues to be associated with the transactions when the information is consolidated or shared among information supply chain partners.

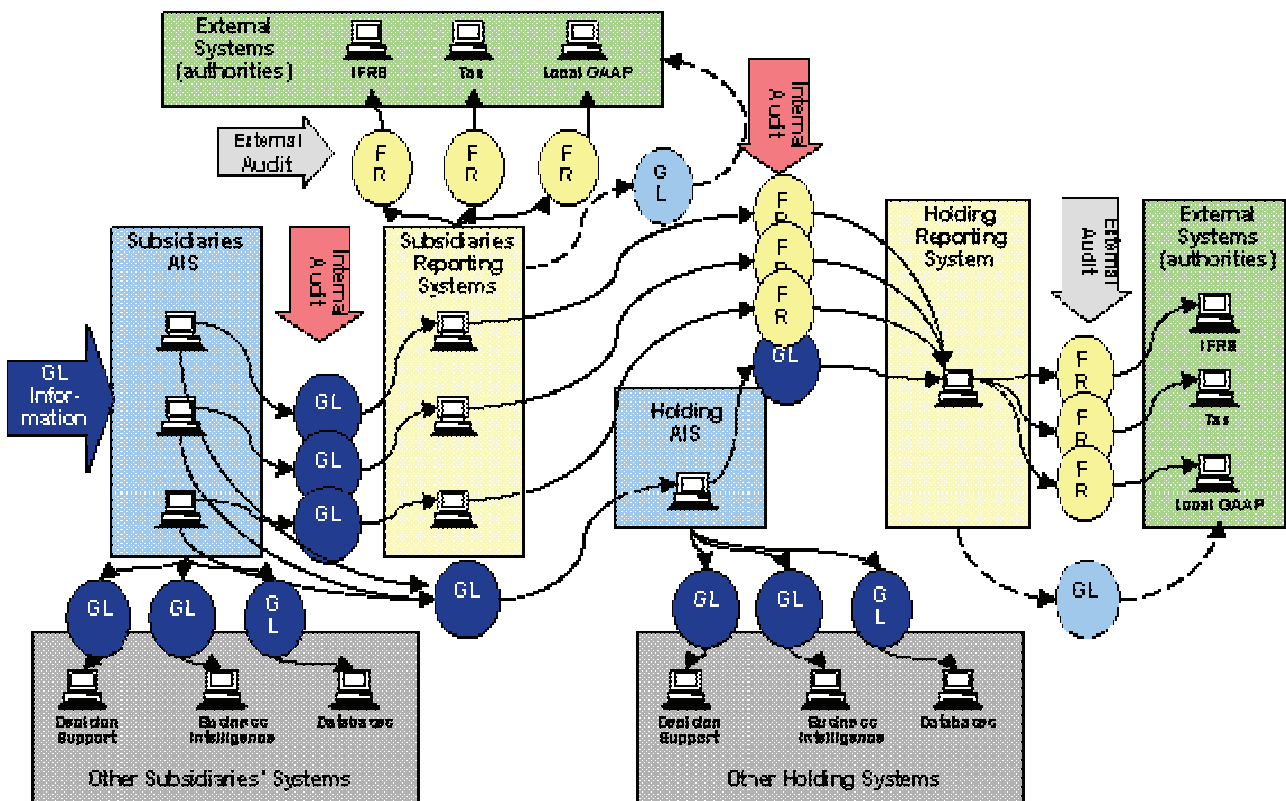

Figure 2. The Roles of XBRL GL. Macdonald, *et al.* presentation to 13th XBRL International Conference, Madrid

Line numbers correspond to line numbers in Appendix A.

```

28<gl-cor:entityInformation>
29 <gl-bus:organizationIdentifiers>
30 <gl-bus:organizationIdentifier contextRef="now">Company Name</gl-
    bus:organizationIdentifier>
31 </gl-bus:organizationIdentifiers>
32</gl-cor:entityInformation>

34<gl-cor:enteredBy contextRef="Now">William</gl-cor:enteredBy>

48<gl-cor:identifierContactFirstName contextRef="Now">John</gl-cor:identifierContactFirstName>
49<gl-cor:identifierContactLastName contextRef="Now">Smith</gl-cor:identifierContactLastName>
50<gl-cor:identifierContactType contextRef="Now">Salesperson</gl-cor:identifierContactType>
51<gl-cor:identifierContactPhoneNumber contextRef="Now">555 555 5555</gl-cor:identifierContactPhoneNumber>
52<gl-cor:identifierContactPhoneNumberDescription contextRef="Now">direct</gl-
cor:identifierContactPhoneNumberDescription>
53</gl-cor:identifierReference>

58<gl-cor:dateAcknowledged contextRef="Now">2007-03-30</gl-cor:dateAcknowledged>
61<gl-cor:shipFrom contextRef="Now">North Carolina</gl-cor:shipFrom>

```

Figure 3. Segments of an XBRL Global Ledger Instance Document for Purchase Orders

One of the desired benefits of XBRL (FR and GL) is the ability to support roll-up and drill-down. However, XBRL FR does not have the tools to support this. To address this deficiency and in response to the need to link the numbers in end reports with the supporting detail, XBRL International published a Public Working Draft in May 2007 entitled, *XBRL Global Ledger Framework – SRCD Module*. “SRCD (Summary Reporting Contextual Data) is a module of the XBRL Global Ledger Framework (XBRL GL) designed to facilitate the link between detailed data represented with XBRL GL and end reporting represented with XBRL for financial reporting (XBRL FR) or other XML schemas” (XBRL International, Inc., 2007). Given its role in supporting internal reporting and its potential to facilitate roll-up to external reporting, XBRL GL contributes to improved information flow through the financial reporting supply chain as illustrated in Figure 4.

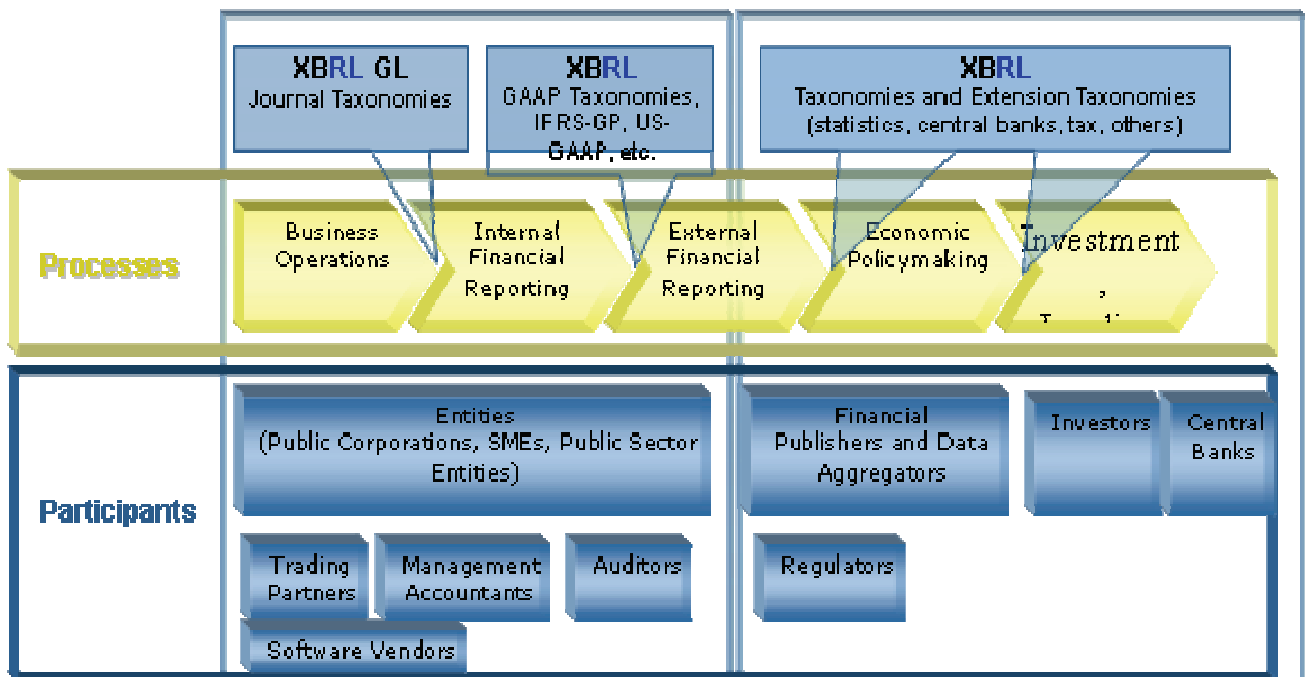

Figure 4. The Financial Reporting Supply Chain Available at <http://www.xbrl.org>

Like all XBRL taxonomies, XBRL GL is extensible to meet the diverse needs of internal reporting. This is particularly important in the area of internal reporting and sharing information across the supply chain as there is greater diversity at the internal and supply chain levels since they are not governed by external reporting requirements. Because the internally-generated taxonomy extensions will need to be maintained indefinitely in the same manner as external taxonomies to provide a stable reference, it is important to plan carefully to reduce the number of changes needed.⁴ With sufficient forethought the extended taxonomy will likely require minimal periodic changes unless there is a change in the underlying XBRL taxonomy. However, these extensions have the potential to create consistency problems. Therefore, versioning must be considered. Versioning each of the subsequent taxonomies is essential. In an effort to address the potential versioning problems, the International Accounting Standards Committee Foundation Taxonomy Development Team is undertaking a three phase project. Currently the second phase has been completed and it is possible to create a linkbase between two taxonomy versions with the Versioning Reporter available on the

⁴ The term “extension” refers to providing tags to information not currently contained in the relevant XBRL taxonomy. They are important, because the information cannot be reported using XBRL without them.

IASF website (www.xbrl-ifs.org/versioning/phase2/demonstrator.html). Corporations will need to look to the IASC and XBRL International for best practices with regard to versioning.

The technical building blocks of XBRL GL are document information (docInfo), entity information (entityInfo) and the entry header (entryHeader). The technical aspects of XBRL GL are covered in Appendix A. We believe that readability and flow are enhanced through an annotated example rather than including a line-by-line discussion in the text.⁵

Another significant benefit offered by XBRL (both FR and GL) is that it provides a method to express semantic meaning and a means to validate the content of an instance document against that semantic meaning based upon taxonomy defined relationships. XBRL GL provides the ability to validate business rules and formulas at various levels within the organization. As seen on line 47 of the Appendix, internal controls are built into the taxonomy through fixed type lists. From this example, we could use the fixed type list for the identifier type (identifierType) to validate that AAA Auto Supply is a valid Vendor. We can test the specific organization rules, as well as standard business rules.

XBRL GL has the potential to change how information is consolidated and shared within an organization, and along the financial information supply chain. Consequently, it has the potential to provide support for both financial reporting and the audit process, acting as a catalyst for change in these areas as well. Organizations that embrace XBRL GL are likely to gain strategic benefits by leveraging their business rules.

3. REA AND XBRL UNITE

In order to maximize the potential benefits of XBRL GL the organization must determine which financial and non-financial information to capture. When an organization decides to use XBRL for internal reporting it begins with the XBRL GL taxonomy and extends it for industry and company specific items. Given the necessity of extensions to support diverse internal reporting needs it is advantageous to have a semantic model (e.g., REA) to add structure to the extension process. XBRL GL allows organizations to tag data so that they can build on and leverage the business rules that

⁵ While the example was hand-coded, instance documents mapped to the XBRL GL taxonomy can be prepared using available software, such as, Altova's Mapforce.

they develop through the use of the REA model to gain a strategic advantage in the global marketplace. The REA ontology helps to pull together the semantics of internal business reporting. By addressing the question of what kinds of common information to represent across organizations and nuances to represent within the organization, REA can help to guide the development and extension of the XBRL GL taxonomy. The synergies available from the combination of REA and XBRL (i.e., reusability, extensibility, and interoperability) can benefit organizations worldwide.

Process models and supporting software are needed to provide the logic and direction for mapping XBRL GL into the REA ontology.⁶ In this section we describe a process model, REA, which provides a logical framework for extending the XBRL GL taxonomy. The process models are the designs “behind the scene” of preferred courses of action for extending taxonomies to improve and expand business reporting. The raw data, as defined by the REA model provided in the policy infrastructure is collected and either tagged at that point (in accordance with the appropriate taxonomy) or it is stored and tagged at the point of instance document creation. By conceptually preparing a taxonomy extension in accordance with the REA ontology and technically in accordance with the XBRL Specification, organizations will produce more comparable data by consistently applying the same set of procedures across time.

Figure 5 presents the proposed XBRL GL taxonomy extension process in detail at the policy level. XBRL GL is inherently rich with elements to support both traditional accounting artifacts (e.g., accounts and balances) and elements that would typically be associated with the REA model (e.g., commitments and the people involved in the processes). The policy level mapping process to the GL taxonomy or creating an extension is likely to be more static than the process at the accountability infrastructure level. Policy level changes would occur when there are changes in corporate policy. Recall that this level represents “what should occur.” Our framework depicts the three basic configuration phases (i.e., Value-Chain Configurations, Process Configurations, and Task Configurations) outlined by Geerts and McCarthy (2002). However, in our forthcoming example we exclude the Task Configuration phase⁷, because according to Geerts and McCarthy (p. 5) “tasks are REA compromises where some occurrences in time are important enough to be specified but not important enough to be represented individually and tracked.”

⁶ While primitive, software applications such as Altova’s MapForce are currently available.

⁷ The Task Configuration phase is the result of the decomposition of the process configurations.

The process begins in the REA Value-Chain Configurations phase (phase one), where the REA process type is identified. Our example uses an acquisition process type. The ordering process is covered by the XBRL GL taxonomy; therefore, we do not need to extend the taxonomy in accordance with the REA ontology and XBRL Specification for this process. The answer to the first question in phase one of Figure 5 (Is a REA process type tag defined by the XBRL GL external taxonomy?) is “Yes” and the next step is to proceed to phase two. It is important to note that many routine business processes are incorporated into the XBRL GL taxonomy. These processes have “Type” tags with enumerated responses that allow for processing by automated systems (i.e., Appendix A, line 54).

In phase two, REA Process Configurations, the economic resource type, economic event type, economic agent type, and commitment type are identified. Because the resource, event, agent and commitment in the accountability infrastructure inherit the characteristics of their respective type, the validity of the resource, event, agent and commitment can be tested. For example, is the agent involved in the acquisition process properly classified as a purchasing agent for the resource type being acquired? The testing of the proper matching of the resource, event, agent, or commitment type could occur during the internal or external audit process or through computerized validations.⁸

Figure 6 provides the details for continuing our example in the following discussion. The commitment type is an order. Following our example, the resource type includes “direct materials inventory” and “indirect materials inventory.” There are multiple economic event types. For example, within the Order Type there are ‘routine orders’ and “special orders.” Agent types include the purchase agent type (i.e., “factory level” and “corporate level”). After searching the GL taxonomy for the resource, event, agent and commitment type tags, we determine that tags exist for the “identifierType” (Appendix A, line 47) and the “documentType” (Appendix A, line, 50); however, tags do not exist for the agent type, vendor type, order type or inventory type.⁹ Since we have not previously extended the taxonomy for this organization the tags do not exist in an available extension taxonomy.¹⁰ Therefore, we need to extend the taxonomy in accordance with the REA ontology and XBRL Specification to tag the resource, event, agent and commitment type.

⁸ As an example, validations are performed on bank Call Report data before the data are sent to the Federal Financial Institutions Executive Council.

⁹ The taxonomy tags added appear in the Figure 9 instance document as line numbers 34b, 47b, 54b and 64b.

¹⁰ If we had previously extended the taxonomy to include an element it would not be necessary to do so again.

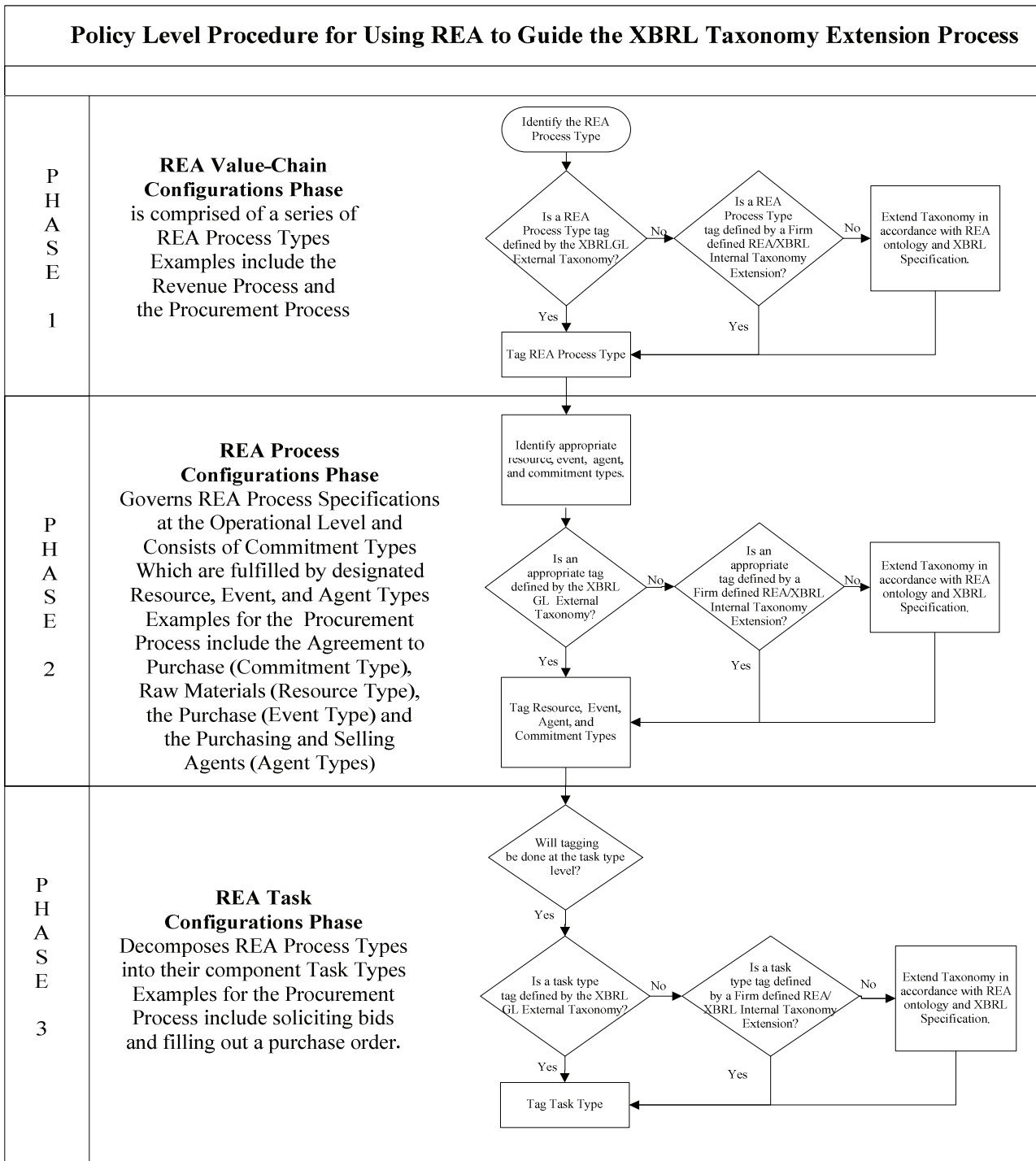

Figure 5. Proposed REA/XBRL Taxonomy Extension Process (Policy Level)

Process Type:	Acquisition Process
Commitment	Requisition
Type:	Order
Resource Type:	Direct Materials Inventory
	Indirect Materials Inventory
Receive	Factory Receiving Dock
Inventory Type:	Distribution Center Receiving Dock
Payment Type:	Check
	Electronic Fund Transfer
Supplier Type:	Within Company Transfer
	Domestic Supplier
Purchase Agent	Factory Level Purchase Agent
Type:	Corporate Level Purchase Agent
Receiving Clerk	Factory Receiving Clerk
Type:	Distribution Center Receiving Clerk

Figure 6. Inventory Acquisition Typification Example

Figure 7 illustrates our proposed REA/XBRL taxonomy extension process in detail at the accountability infrastructure level. Recall that the accountability infrastructure represents the instantiations of the commitment, resource, event, and agent types defined in the policy infrastructure. While not an extension, the element “identifierDescription” (line 46) is an instantiation that can be matched to the “identifierType” (line 47) and “vendorType” (line 47b). Our framework depicts three basic operational phases: Value-Chain Specifications, Process Specifications, and Task Specifications. As with the policy infrastructure, we exclude the Task Specification phase from the example. The process for taxonomy extension is essentially the same as in the policy infrastructure phase, except we are extending the taxonomy for specific instantiations that correspond to the type tags. First, for the REA Value-Chain specifications phase, identify, match, and tag the REA process (i.e., “inventory acquisition”). Second, for the REA Process Specifications phase, identify and tag the economic commitment along with the economic resources, economic events, and economic agents. We do not extend the taxonomy for any elements at the accountability infrastructure level due to the inherent richness of the XBRL GL taxonomy and the desire to maintain simplicity in our example.

Details for our continuing example are included in Figure 8. In our example, the economic commitment is a “routine order”. A “fan motor” or “engine” would be an example of the direct materials inventory. The routine order event may be “level 1” or “level 2,” which may correspond to the dollar value of the order. The purchase agent at the factory level might be “William” or “Michelle.” In addition, the validity of the resource, event, agent and commitment types could be confirmed for example that “fan motor” is a valid for the “direct materials” resource type. Recall that valid types can be controlled in the taxonomy extension, as in the GL taxonomy, through the use of a fixed type list. The use of fixed type lists enhances internal controls.

The effect of extending the 2006 XBRL GL taxonomy for the additional non-financial information captured as a result of using the REA ontology can be seen in Figure 9. This figure presents a portion of an instance document with XBRL tags for the procurement process example. The line numbers correspond to the line numbers in the abbreviated instance document in Appendix A. By tagging the data and maintaining the relationship between the resources, events, agents, and commitments organizational decision making can be enhanced through more timely, higher quality decision making processes.

To summarize, our framework addresses some of the problems that have been encountered in trying to implement the use of XBRL GL (e.g., XML’s lack of semantics) by guiding the development of taxonomies and customized extensions in a rational and systematic manner in accordance with the REA ontology. Current technology is sufficient to implement our framework. For example, Altova MapForce and Fujitsu’s Taxonomy Editor and Instance Creator with the available XBRL GL add-in can be used to map the information from the company database to the XBRL GL taxonomy. However, before the applicable software is chosen, management should review their organizational processes to decide what data needs to be captured and tagged. The use of the REA ontology and our framework would be used to design the policy and accountability infrastructures.

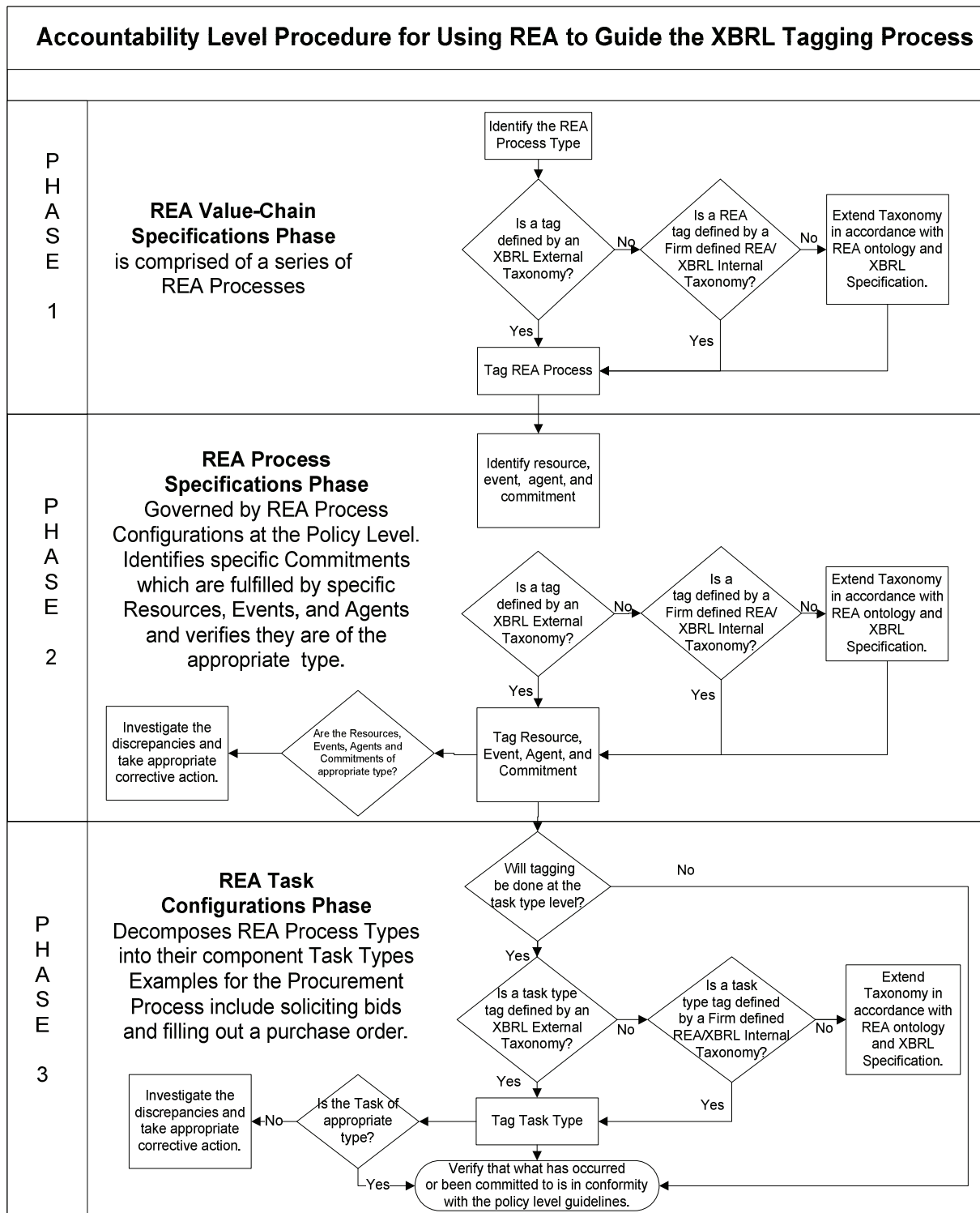

Figure 7. Proposed REA/XBRL Taxonomy Extension Process (Accountability Level)

4. CONCLUSIONS

Our paper examines the importance of having a business reporting system capable of efficiently capturing and communicating key financial and non-financial business information and performance measures within a firm and across the business supply chain. Given the weaknesses of traditional business reporting systems in performing this task and adhering to the needs of the organization, we propose a framework to address these needs by combining REA with XBRL GL. An organization-wide REA business reporting system could supply semantic, efficiency, and interoperability gains that would provide early adopters a competitive advantage in their industry and continue to meet its dynamic reporting needs. In the spirit of design science, we present a process framework to illustrate how REA could be used to guide the XBRL GL taxonomy extension process within an organization. Utilizing REA to guide the XBRL taxonomy extension process within the organization could also have the added benefit of helping management to better understand their organization and identify opportunities for improvement.

Process:	Inventory Acquisition	Payment:	Check
Commitment:	Office Supplies Acquisition		<i>Checking Account 1</i>
	Requisition		<i>Checking Account 2</i>
	Raw Materials		Electronic Fund Transfer
	Supplies		<i>Checking Account 1</i>
	Order		<i>Checking Account 3</i>
	<i>Routine Order</i>	Supplier:	Within Company Transfer
	<i>Special Order</i>		<i>Division A</i>
Resource:	Direct Materials Inventory		<i>Division B</i>
	<i>Fan Motor</i>		Domestic Supplier
	<i>Engine</i>		<i>AAA Auto Supply</i>
	<i>Brake Assembly</i>		<i>Reliable Motors</i>
	Indirect Materials Inventory	Purchase Agent:	Factory Level Purchase
	<i>Grease</i>	Agent	<i>William</i>
	<i>Bolt</i>		<i>Michelle</i>
Receive Inventory:	Factory Receiving Dock		Corporate Level Purchase
	Robert		<i>Jason</i>
	Susan	Agent	<i>Megan</i>
	Distribution Center		Factory Receiving Clerk
Receiving Dock		Receiving Clerk:	<i>Justin</i>
	Jeffrey		<i>Jacob</i>
	Roger		Distribution Center
		Receiving Clerk	<i>Joshua</i>
			<i>Risk</i>

Figure 8. Inventory Acquisition/Payment Accountability

Line numbers correspond to line numbers in Appendix A. Line numbers 34b, 47b, 54b and 64b are the result of the type tags included in the taxonomy extension.

```

34<gl-cor:enteredBy contextRef="Now">William</gl-cor:enteredBy>
34b<APF:purchaseAgentType contextRef="Now">Factory_Level</APF:purchaseAgentType>

44<gl-cor:identifierReference>
45<gl-cor:identifierCode contextRef="Now">100</gl-cor:identifierCode>
46<gl-cor:identifierDescription contextRef="Now"> AAA Auto Supply</gl-cor:identifierDescription>
47<gl-cor:identifierType contextRef="Now">V</gl-cor:identifierType>
47b<APF:vendorType contextRef="Now">Domestic</APF:vendorType>
53</gl-cor:identifierReference>

54<gl-cor:documentType contextRef="Now">order-vendor</gl-cor:documentType>
54b<APF:orderType>Routine</APF:orderType>

64<gl-bus:measurableCode contextRef="Now">IN</gl-bus:measurableCode>
64b<APF:inventoryType contextRef="Now">Direct Materials</APF:inventoryType>
65<gl-bus:measurableID contextRef="Now">Fan Motor</gl-bus:measurableID>

```

Figure 9. An Instance Document Incorporating an XBRL GL Taxonomy REA Extension

Information is the key to success in today's fast-paced global marketplace. Being able to use information to act and react quickly allows an organization to gain a strategic advantage over its competitors. A primary benefit to be derived from combining REA and XBRL lies in tagging and sharing information at the economic event level and using that information to make smarter, faster decisions. The specific elements that an organization captures as a result of the REA model allows the organization "to do what it does best" and leverage its business rules. Further advantage can be gained through enhanced internal control validations. Finally, XBRL GL can serve as the bridge between transactions and financial reporting.

More research is needed examining the costs and benefits in combining REA and XBRL GL. While there is considerable debate on this topic within the XBRL community, survey research indicates that participants in the SEC voluntary filing project spent between \$5,000 and \$25,000 for initial filings (Purnhagen 2007).¹¹ If we infer that these

¹¹ Quantitative data is not available for the costs incurred for subsequent filings.

costs would also be reasonable for companies incorporating XBRL GL for internal reporting, it is likely that the potential benefits will outweigh the costs. Specifically, it is difficult to quantify business process efficiencies and interoperability possibilities, but it is reasonable to expect that cost savings achieved through lower data entry costs (such as those achieved through reductions in the need to re-key data in order to share information between disparate systems along with the resulting decreased incidence of human error) and other operational efficiencies could provide for positive future cash flows. Thus, our framework is presented with the assertion that an organization utilizing XBRL GL coupled with a REA semantic model would likely be capable of meeting comprehensive strategic business reporting needs for multiple stakeholders and be fiscally rewarded in the long term.

5. REFERENCES

- DENNA, E. L.; PERRY, L. T.; JASPERSON, J. (1998): "Reengineering and REAL Business Process Modeling", in *Business Process Change: Reengineering Concepts, Methods and Technologies*, edited by M. Khosrowpour and J. Travers: 350-375, Hershey, PA: Idea Group Publishing.
- GARBELLOTO, G. (2006): "Exposing Enterprise Data: XBRL GL, Web Services, and Google, Part 1", *Strategic Finance*, August: 59-61.
- GEERTS, G. L. (2004): "An XML Architecture for Operational Enterprise Ontologies", *Journal of Emerging Technologies in Accounting*, vol. 1: 73-90.
- GEERTS, G. L.; MCCARTHY, W. E. (1997): "Modeling Business Enterprises as Value-added Process Hierarchies with Resource-Event-Agent Object Templates", in *Business Object Design and Implementation*, edited by J. Sutherland and D. Patel: 94-113, Springer Verlag: Berlin and Heidelberg, Germany.
- GEERTS, G. L.; MCCARTHY, W. E. (2000): "Augmented Intensional Reasoning in Knowledge-based Accounting Systems", *Journal of Information Systems*, Fall: 127-150.
- GEERTS, G. L.; MCCARTHY, W. E. (2002): "An Ontological Analysis of the Economic Primitives of the Extended-REA Enterprise Information Architecture", *International Journal of Accounting Information Systems*, vol. 3, n. 1: 1-16.
- HEVNER, A. R.; MARCH, S. T.; JINSOO, P.; RAM, S. (2004): "Design Science in Information Systems Research", *MIS Quarterly*, vol. 4, n. 2: 75-105.
- IJIRI, Y. (1975): *Theory of Accounting Measurement*. American Accounting Association.

MACDONALD, J. (moderator); OCHOCKI, B.; PIECHOCKI, M.; SCHMITT, H.: May 17, 2006. Presentation to 13th XBRL International Conference, Madrid, Spain.

MCCARTHY, W. E. (1982): “The REA Accounting Model: A Generalized Framework for Accounting Systems in a Shared Data Environment”, *The Accounting Review*, vol. 57, n. 3: 554-578.

NAKAMURA, H.; JOHNSON, R. (1998): “Adaptive Framework for the REA Accounting Model”, paper presented at Object-Oriented Programming, Systems, Languages and Applications (OOPSLA) Conference, Vancouver, British Columbia.

PURHAGEN, G. (2007): Presentation to 7th Annual Bryant University XBRL Conference, October 19. Merrill Corporation white paper of survey results.

SIMON, H. A. (1996): *The Sciences of the Artificial* (3rd ed.). Cambridge, MA: MIT Press.

XBRL INTERNATIONAL, INC. (2007): *XBRL Global Ledger Framework – SRCD Module – Public Working Draft Overview* (May 23). Gianluca Garbellotto and Eric Cohen Editors, <http://www.xbrl.org/int/gl/2007-05-23/XBRL-Global-Ledger-Framework-SRCD-PWD-2007-05-23.rtf>

XBRL-IFRS.ORG/VERSIONING/PHASE2/DEMONSTRATOR.HTML. Last accessed October 8, 2007.

XBRL.ORG. Last accessed October 8, 2007.

XBRL.ORG/GLTAXONOMY. Last accessed October 8, 2007.

XBRL.ORG/INT/GL/2007-04-17/GLFRAMEWORK-REC-2007-04-17.HTM. Last accessed April 30, 2007.¹²

¹² This reference is only cited in Appendix A.

APPENDIX A

XBRL GL Instance Document Example

Annotations precede the lines discussed. Line numbers are indicated only for the lines of code.

<!--The standard root element and the location of the taxonomy files -->

1 <?xml version="1.0" encoding="UTF-8"?>

2 <!-- Generated by Fujitsu XWand B0070 -->

3 <xbrli:xbrl xmlns:xbrli="http://www.xbrl.org/2003/instance"

xmlns:link="http://www.xbrl.org/2003/linkbase"

xmlns:xlink="http://www.w3.org/1999/xlink"

xmlns:gl-plt="http://www.xbrl.org/int/gl/plt/2006-10-25"

xmlns:gl-cor="http://www.xbrl.org/int/gl/cor/2006-10-25"

xmlns:gl-muc="http://www.xbrl.org/int/gl/muc/2006-10-25"

xmlns:gl-bus="http://www.xbrl.org/int/gl/bus/2006-10-25"

xmlns:iso4217="http://www.xbrl.org/2003/iso4217">

4 <link:schemaRef xlink:type="simple" xlink:href="gl-plt-2006-10-25.xsd"/>

<!-- While contexts are mandatory according to XBRL Specification 2.1, they are included for convention rather than to convey information in XBRL GL. The GL working group recommends that the file creation date be used as the period. In addition, CUSIP number provides a better identifier than the company name -->

5 <xbrli:context id="Now">

6 <xbrli:entity>

7 <xbrli:identifier

 scheme="http://www.CompanyName.com">CUSIPnumber</xbrli:identifier>

8 </xbrli:entity>

9 <xbrli:period>

10 <xbrli:instant>2007-03-31</xbrli:instant>

11 </xbrli:period>

12</xbrli:context>

<!-- As with the context, units are provided by convention and should not be relied upon -->
13<xbrli:unit id="USD">
14 <xbrli:measure>iso4217:USD</xbrli:measure>
15</xbrli:unit>

<!-- AccountingEntries is the “container” for XBRL GL. Multiple accountingEntries tuples can appear within a single instance document. The accountingEntries tuple may represent transactions and/or master files. The distinction would be signified by the entriesType value. Multiple accountingEntries sections can be used to reduce data redundancy. -->

16<gl-cor:accountingEntries>

<!-- DocumentInfo is required because of the use of entriesType -->

17<gl-cor:documentInfo>

<!-- The use of entriesType “other” provides guidance to automated systems that are processing the information contained in this document. -->

18<gl-cor:entriesType contextRef="Now">other</gl-cor:entriesType>

<!-- A unique identifier for this group of information -->

19<gl-cor:uniqueID contextRef="Now">001</gl-cor:uniqueID>

<!--The language, “English.” -->

20<gl-cor:language contextRef="Now">iso639:en</gl-cor:language>

<!-- The date associated with the creation of the date contained within the accountingEntries structure. -->

21<gl-cor:creationDate contextRef="Now">2007-05-13</gl-cor:creationDate>

<!-- Who created the information contained within the accountingEntries structure.

22<gl-bus:creator contextRef="Now">Paper Authors</gl-bus:creator>

<!-- A description of the batch of information. -->

23<gl-cor:entriesComment contextRef="Now">Purchase Order Example</gl-cor:entriesComment>

<!-- The time period for the purchase orders, although in our example only one purchase order is shown -->

24<gl-cor:periodCoveredStart contextRef="now">2007-03-01</gl-cor:periodCoveredStart>
25<gl-cor:periodCoveredEnd contextRef="now">2007-03-31</gl-cor:periodCoveredEnd>
26<gl-muc:defaultCurrency contextRef="now">iso4217:usd</gl-muc:defaultCurrency>

27</gl-cor:documentInfo>

<!-- The entityInformation tuple is used to contain information about the company (e.g. company name) -->

28<gl-cor:entityInformation>

29<gl-bus:organizationIdentifiers>

30<gl-bus:organizationIdentifier contextRef="now">Company Name</gl-bus:organizationIdentifier>

31</gl-bus:organizationIdentifiers>

32</gl-cor:entityInformation>

<!-- The entryHeader and entryDetail structures are likely to be necessary to capture most business information. A single document is represented at the entryHeader level, note that all entryDetail structures for the purchase order are nested within the entryHeader start and end tags. Documents are defined at the line level, as seen subsequently the information about each line item on a form (purchase order in this example) is maintained within the entryDetail structure. -->

33 <gl-cor:entryHeader>

<!-- For internal control or audit purposes it may be important to know who entered the transactions -->

34<gl-cor:enteredBy contextRef="Now">William</gl-cor:enteredBy>

<!-- When were the transactions entered into the system, this may be relevant for future analysis of whether transactions were recorded in the correct period -->

35<gl-cor:enteredDate contextRef="Now">2007-03-31</gl-cor:enteredDate>

<!-- The use of source journal ID allows for the sharing of information across users because this ID conforms to a fixed list of source journal ID types embedded in the XBRL GL taxonomy-->

36<gl-cor:sourceJournalID contextRef="Now">pj</gl-cor:sourceJournalID>

<!-- The description of the source journal name in use by the company -->

37<gl-bus:sourceJournalDescription contextRef="Now">Purchases Journal</gl-bus:sourceJournalDescription>

<!-- These entries were entered manually. We could use this tag to indicate that the entries had been imported from an automated accounting system. -->

```
38<gl-bus:entryOrigin contextRef="Now">manual</gl-bus:entryOrigin>
<!-- The entryNumber tag can be used to represent the documentNumber. -->
39<gl-cor:entryNumber contextRef="Now">1</gl-cor:entryNumber>
<!--Why the entry is being made -->
40<gl-cor:entryComment contextRef="now">Purchase Order: #12345 Vendor: #100</gl-
cor:entryComment>
<!-- Individual lines of information are represented using the entryDetail structure, all of the
lines of the document are held together with the entryHeader -->
41<gl-cor:entryDetail>
<!-- A unique identifier for each detail line. -->
42<gl-cor:lineNumberCounter decimals="0" contextRef="Now" unitRef="USD">1</gl-
cor:lineNumberCounter>
<!-- This would be the extended amount of this line item on the invoice -->
43<gl-cor:amount decimals="0" contextRef="Now" unitRef="USD">11500</gl-cor:amount>
<!-- Information about the vendor is contained in the identifier structure. -->
44<gl-cor:identifierReference>
<!-- The vendor number. -->
45<gl-cor:identifierCode contextRef="Now">100</gl-cor:identifierCode>
<!-- The vendors name. -->
46<gl-cor:identifierDescription contextRef="Now"> AAA Auto Supply</gl-
cor:identifierDescription>
<!-- The enumerated identifierType as defined by the taxonomy allows for processing by
automated systems. -->
47<gl-cor:identifierType contextRef="Now">V</gl-cor:identifierType>
<!-- The following five tags are the contact person's first and last name, their role, phone
number, and information that it is a direct contact phone number. -->
48<gl-cor:identifierContactFirstName contextRef="Now">John</gl-
cor:identifierContactFirstName>
49<gl-cor:identifierContactLastName contextRef="Now">Smith</gl-
cor:identifierContactLastName>
50<gl-cor:identifierContactType contextRef="Now">Salesperson</gl-cor:identifierContactType>
```

51<gl-cor:identifierContactPhoneNumber contextRef="Now">555 555 5555</gl-cor:identifierContactPhoneNumber>

52<gl-cor:identifierContactPhoneNumberDescription contextRef="Now">direct</gl-cor:identifierContactPhoneNumberDescription>

53</gl-cor:identifierReference>

<!-- The identifierType as “V” for “vendor” and the documentType as “order-vendor” allows automated systems to discern that this batch of information is orders placed with vendors.-->

54<gl-cor:documentType contextRef="Now">order-vendor</gl-cor:documentType>

<!-- The name that our company uses for the documentType classified as order-vendor by XBRL GL.-->

55<gl-cor:documentTypeDescription contextRef="Now">Purchase Order</gl-cor:documentTypeDescription>

<!-- DocumentNumber is the purchase order number. -->

56<gl-cor:documentNumber contextRef="Now">12345</gl-cor:documentNumber>

<!-- Essentially the same as the documentReference. -->

57<gl-cor:detailComment contextRef="Now">Vendor #:100 Document # :12345</gl-cor:detailComment contextRef="Now">

<!-- The date the order was acknowledged by the vendor -->

58<gl-cor:dateAcknowledged contextRef="Now">2007-03-30</gl-cor:dateAcknowledged>

<!-- The date the order availability was confirmed. -->

59<gl-cor:confirmedDate contextRef="Now">2007-03-31</gl-cor:confirmedDate>

<!-- Currently the terms attribute is undefined. According to the xbrl.org website the XBRL GL Working Group has discussed the adoptions of an enumerated structure for this attribute. -->

60<gl-cor:terms contextRef="Now">2/10, n/30</gl-cor:terms>

<!-- Where the vendor ships the item from. This information may be relevant in production planning. -->

61<gl-cor:shipFrom contextRef="Now">North Carolina</gl-cor:shipFrom>

<!-- The method of payment that we have agreed upon with the vendor. -->

62<gl-bus:paymentMethod contextRef="Now">EFT</gl-bus:paymentMethod>

<!-- The measurable data structure is used to represent information at the line item level. The elements within the structure can represent items which are matched to a code rather than a financial statement account. The information can be both numeric and non-numeric. In general a purchase order would have a single measurable item per line in the entryDetail. The measurableQuantity multiplied by the measurableCostPerUnit will equal the amount tag above.

63<gl-bus:measurable>

64<gl-bus:measurableCode contextRef="now">IN</gl-bus:measurableCode>

65<gl-bus:measurableID contextRef="now">Fan Motor</gl-bus:measurableID>

66<gl-bus:measurableDescription contextRef="now">1 hp Fan Motor</gl-bus:measurableDescription>

67<gl-bus:measurableQuantity contextRef="now" decimals="2" unitRef="NotUsed">100</gl-bus:measurableQuantity>

68<gl-bus:measurableUnitOfMeasure contextRef="now">Each</gl-bus:measurableUnitOfMeasure>

69<gl-bus:measurableCostPerUnit contextRef="now" decimals="2" unitRef="usd">115</gl-bus:measurableCostPerUnit>

70</gl-bus:measurable>

<!-- The close tag for this line on the purchase order. -->

71</gl-cor:entryDetail>

<!--The instance document would continue with other line items on the same purchase order and additional purchase orders that make up this instance document. These have been excluded for the sake of brevity. The end tags for the accountingEntries and the instance document follow -->

72</gl-cor:accountingEntries>

73</xbrli:xbrl>