

THE SYNTAX OF VOICED PALATALS IN SPANISH

PALOMA GARCÍA-BELLIDO

The properties of Voiced Palatal Simplification (VPS) are of interest to any theory which investigates how linguistic elements match and what effects their matching triggers. This analysis supports models in cognitive linguistics where the selection for production is derived from the effects of an inhibitory process which lowers activation levels in one of the two matched linguistic items (Green, 1998; Poulisse, 1997).

It is argued on empirical grounds that VPS fails to be analysed as the movement of a Voiced Palatal (VP) in Phonetic Form (PF) to a site S where its voiced palatality is checked against that of another VP in S, and its PF is subsequently deleted. Instead it is argued that the matching of VPs is a sufficient but not a necessary condition for VPS. Some specific matchings do not flag their matching. VP matching is a local syntactic operation in the minimalist sense (Chomsky, 1995) subject to operating in a c-command domain. VP matching cannot be activated inside an adjoined structure. It is suggested that all VP matchings fire activation of the matched sites in the form of a transcription. This transcription maps all the Non-Phonetic Form (NPF) features of a matched VP onto a Phonetic Form (PF) which will be available for production. The activation levels of transcription are lowered or dampened by an inhibitory process in all sites where a successful matching has been initiated and flagged. These findings are relevant for theories of language development.

1. INTRODUCTION

In all dialects of Spanish a sequence of voiced palatals (VPs) displays somewhat puzzling behaviour. This behaviour, named here Voiced Palatal Simplification (VPS), has been discussed in a linear generative framework in Harris (1980) and in a non-linear generative approach in García-Bellido (1989, 1999). I will argue here that the interest of this case is that it tests the adequacy of current theoretical models on the effects of linguistic matching. The findings lend support to a cognitive theory which assumes that out of two identical linguistic items (with respect to a given linguistic

feature), the one not in use undergoes an inhibitory process which lowers its activation levels prompting the other match to be in use for language production (Poullisse, 1997; Green, 1998). The findings here suggest that only those VPs which have initiated a successful matching are the ones which are inhibited. However a downward initiator fails to trigger inhibition when the successful matching involves two dependent elements. In order to show these findings first I will argue that standard approaches to prosodic geometry (Template theory: Levin, 1985; Hualde, 1992) and Autosegmental theory (Multi-linked Theory: Khan, 1976) fail to account for the properties of VPs and their interaction with VPS. It will be argued, following the Linear Correspondence Axiom (Kayne, 1984), that VPs, like all segments, are nested in an asymmetric relation (García-Bellido, 1996, 1997, 1999). This novel phonological approach explains why VPS, like other processes, only operate when VPs are in a c-command relation. Secondly, I will argue that a standard movement -trace approach (Chomsky, 1981, 1995) fails on empirical grounds. This leads to the hypothesis that the effects of VPS's can be derived from three distinct mechanisms: a matching process, a transcription process and an inhibitory process. The matching process is assumed to be performed by an Upward Messenger (UM) or a Downward Messenger (DM) present only in combinatorially dependent segments (-I). The movement of VP Messengers is constrained in two ways. First it cannot get out of an adjoined structure. This operational constraint has been found independently in the realm of word-syntax (Huang 1982, Manzinni 1992). Secondly, it stops the search on the first designated site. This is independently found in phonological harmony processes (The Non-crossing constraint: Goldsmith, 1976) and in word syntax (Relativized Minimality: Rizzi, 1990). Once the match has been produced \Leftarrow all matched VPs initiate a transcription \Rightarrow of all their Non- Phonetic Form information into a Phonetic Form \square . There is an asymmetry in that a DM which matches two dependent VPs does not flag its successful matching. The inhibitory process reduces the levels of transcription of all the sites of initiators which have flagged matching.

(A) VPS=M Movement \rightarrow , Matching \leftarrow , Transcription \square , Inhibition \uparrow , Flag —

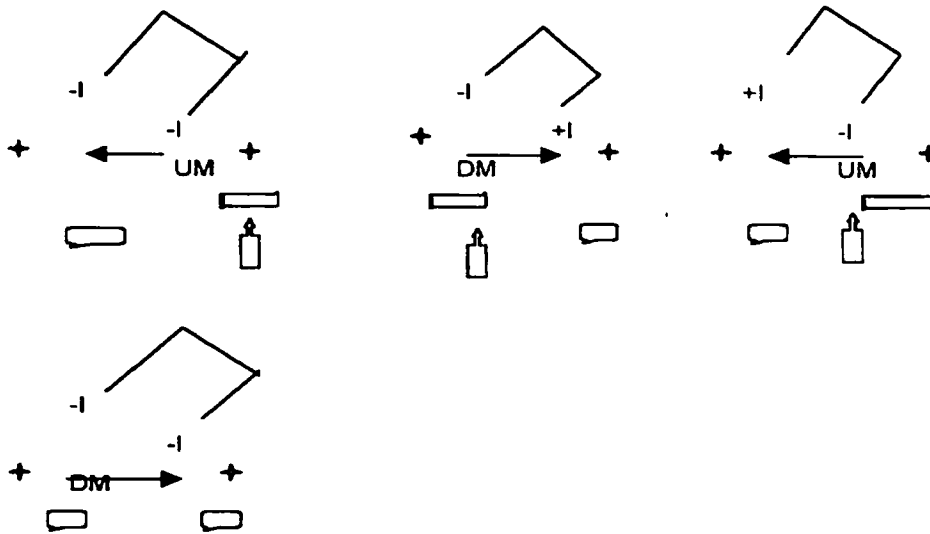

This analysis lends support to the hypothesis that the ability to develop a language depends crucially on having a small set of local combinatorial conditions (Constrained Based Grammars, Bird, 1995) associated with linguistic entities and non destructive operative mechanisms (here inhibitory processes) which are assumed to govern the learning process.

The structure of this paper is as follows. In section § 2, I will present a basic approach to the data. In section §3, I will argue that the Template Theory used profusely for the last twenty four years fails to capture the structure of VP medial consonants and the minimal domain in which VPS operates. In section §4, I will offer a sketch of some fundamental combinatorial conditions associated with Spanish segments which gives rise to both prosodic structures and sound alternation. In this same section I will develop the need for the analysis offered.

2. BASIC DATA

Spanish has a rich set of voiced palatal sounds (Quilis 1981). This set encompasses major categories: Vowel (V) Glide (G) and Consonant (C).¹

(1) Voiced Palatal phones of Spanish

Consonants:	Fricative	[j]	Nasal	[ɲ]
Glide	[j]		Vowel	[i]

The process I will be discussing involves the appearance or non-appearance in the speech chain of voiced palatals. Palatals which are non-voiced, [cç], are not affected by this process: hin[cçje]ndo “plinish+ing” *hin[cçe]ndo. A general statement given in (2a) together with the data (2b) summarises the problem.

(2a) Voiced Palatal Simplification (VPS)

Any voiced palatal may be simplified in contact with another voiced palatal.

- (2b) VG -> V
 GV -> V
 CG -> C
 CV -> CV, V
 VC -> VC, V
 GC -> GC, G
 VV -> VV
 CC -> CC
 VCC -> VCC

3. PROBLEMS FOR STANDARD APPROACHES

In an Autosegmental Theory the effects of VPS may be configurationally expressed by delinking the association line which connects a segment to the syllable template (Goldsmith, 1976; Levin, 1985; Hualde, 1992).² I will first give examples where delinking takes place (3,4,5,6a) followed by those where no delinking is possible (6b,7). I will give examples where VPS applies intrasyllabically (3,5,6) and intersyllabically (4,5,7).

(3) Domain: Intrasyllabic

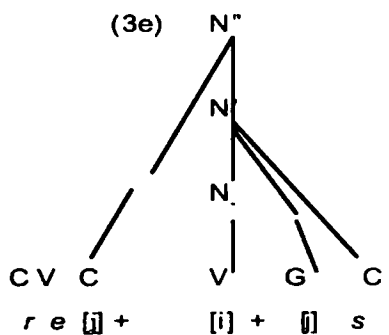
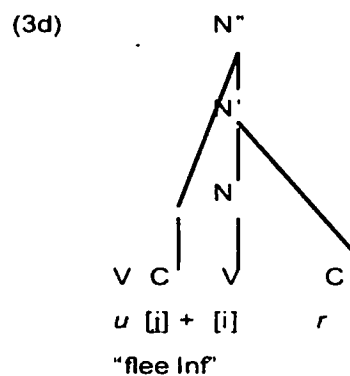
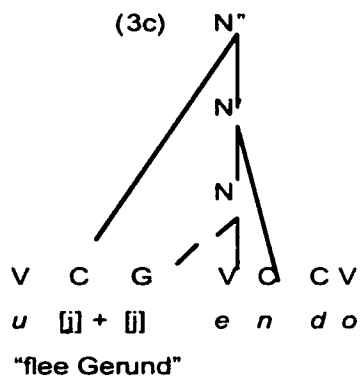
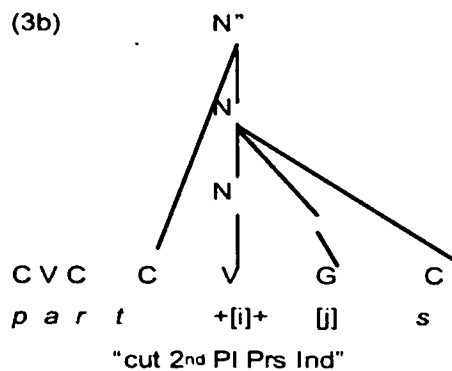
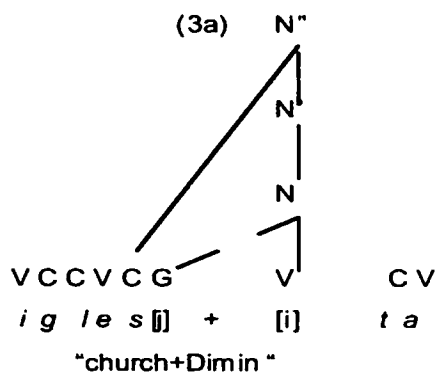

(4) Domain: Intrasyllabic

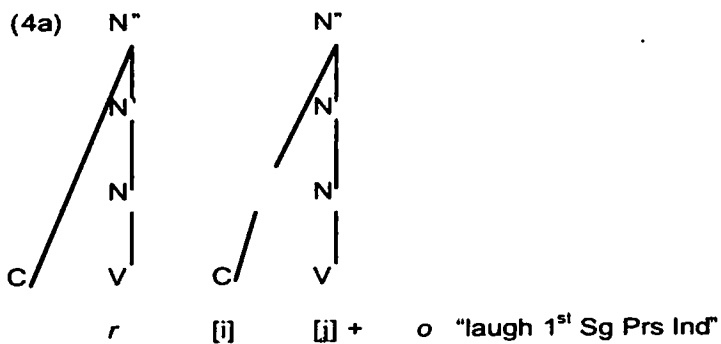

(5) Domains : Intersyllabic and Intrasyllabic

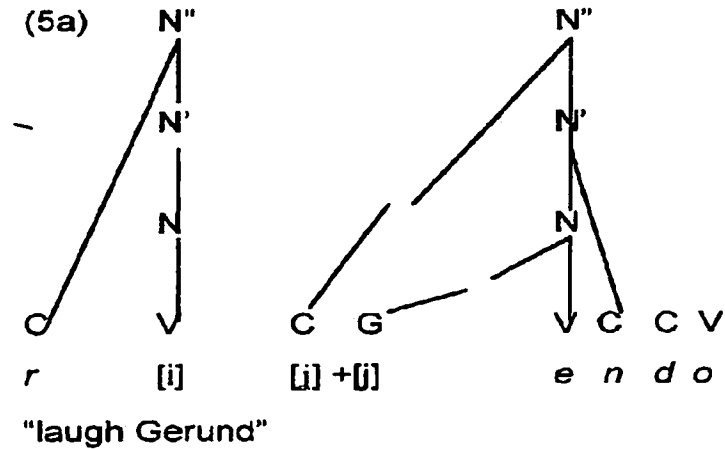

In a standard autosegmental approach to Spanish, any intervocalic consonant in surface representation is an Onset (García-Bellido, 1979; Harris, 1983; Hualde, 1992). Such a concept is responsible for positing "resyllabification".

I will give now examples where delinking does not take place despite the fact that VPs are adjacent to each other. (6a) and (6b) are contrastive.

(6) Domain: Intrasyllabic

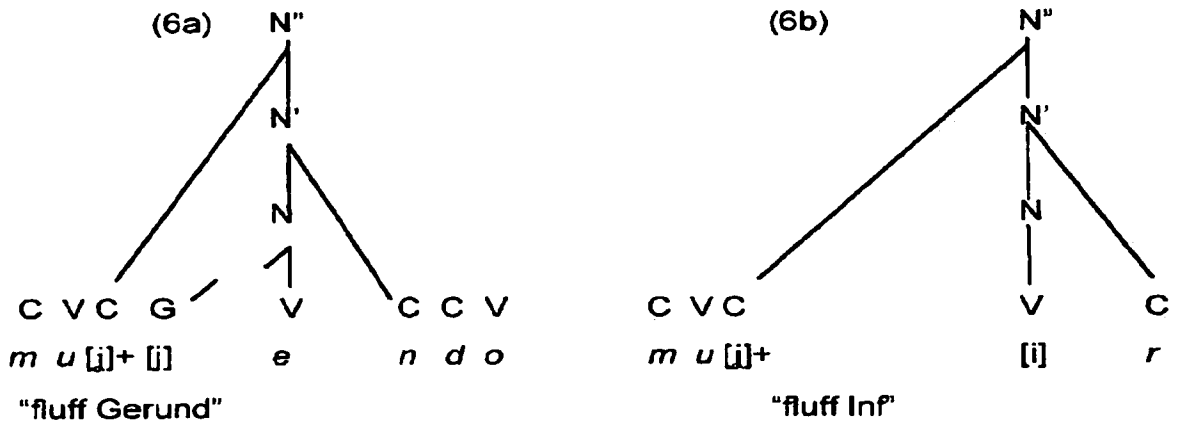

(7) Domain: Intersyllabic

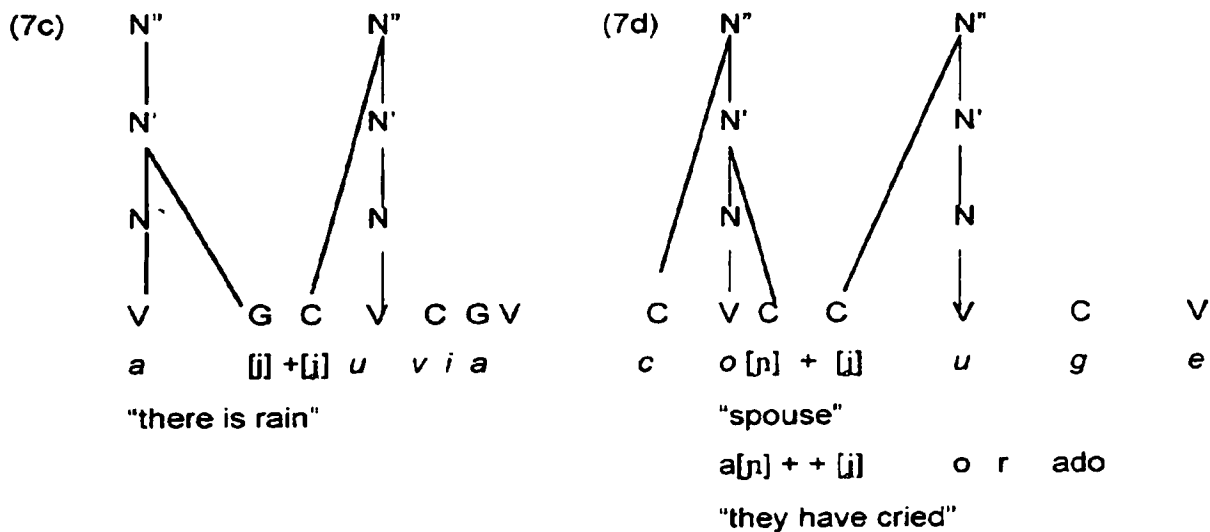
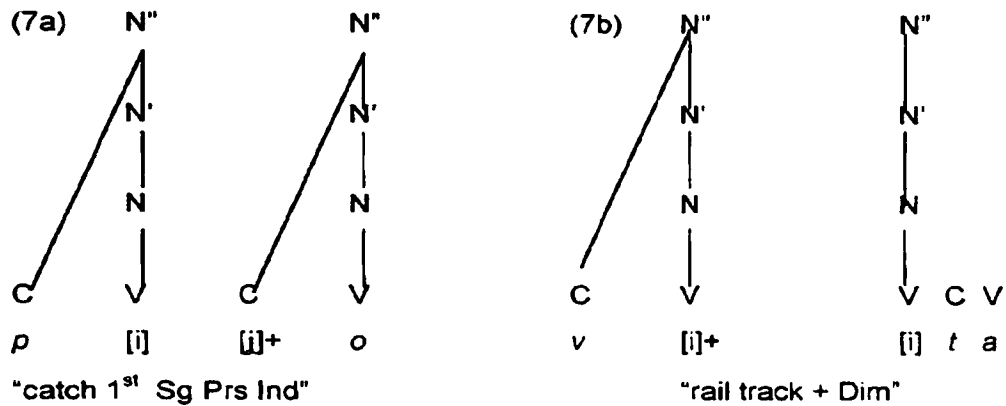

I will show that VPS cannot be explained by a Syllable Template. It has been argued that phonological processes are either segmental or structure-dependent (Sheine and Steriade, 1986). A process is segmental when the categories involved in it are not conditioned by where their position is in the prosodic structure. Thus "spirantisation" in Spanish fits this notion in all analyses. A non-palatal voiced obstruent consonant C assimilates the value of continuancy of any preceding segment U, regardless of the position that C and U may have in the prosodic structure (Mascaró, 1984). A process is structure-dependent when it is restricted by linguistic structure. Thus in some Spanish varieties a glottal fricative [h] occurs postvocally in N' (Harris, 1983).³ If VPS is segmental, then no delinking would be expected in (2a). If VPS is structure-dependent, we do expect it to be confined to some prosodic domain. One of these

prosodic domains could be the syllable. If each syllable has a geometry, we may expect this geometry to provide some fundamental account for how VPS operates. For instance, in (7c) the G and the C are geometrically further apart than they are in (3c). In this comparative approach the geometry of the the standard syllable (Levin, 1985; Hualde, 1992) is useful since it can derive delinking from a locality notion. But this exercise falls apart on empirical grounds. There are cases where VPS delinks intersyllabically (geometrically too far cf. (4a)) and there are cases where delinking does not take place even though the domain is intrasyllabic (geometrically closer cf. (6b)). In (4a) and (5a) the consonant is delinked in contact with the preceding vowel in the preceding Nucleus. Furthermore the same consonant which delinks intersyllabically in (4a) and (5a), delinks intrasyllabically in (3e). Now, suppose that we insist on deriving delinking from a locality principle mapped into a prosodic domain. Suppose we stipulate that the palatal consonant in (3c,3d,3e,4a,5a) is underlyingly attached to N' on the right. Delinking will then have to be extrinsically ordered before resyllabification to allow for delinking in (4a,5a) and after resyllabification, to allow for delinking in (3c,3d,3e). But if the consonant delinks in (5a) before resyllabification, then the glide in (5a) will not delink since the domain is not intrasyllabic. Thus the intrasyllabic constraint falls apart. Moreover there is no current prosodic explanation for why the Consonant in (6b) is immune to delinking while the one in (3d) is not.

We must conclude that either structure dependent rules do not exist or else that they do but the current concept of what a well-formed prosodic structure may be or how a process may work or both is wrong.

I will now show that VPS cannot be explained in an autosegmental multilinked theory.

One of the most fundamental concepts on which the approach I will offer here is based, is on the assumption that there are at least two different types of categories: Medial and non-medial categories. Medial categories have one distinct property. They must occur surrounded by other categories. This explains why they are not found in utterance final or utterance initial position. Children seem to use this structure profusely in their first stages of language development. Priestly (1977) reports that the child under observation mapped adult words using the canonical template [CV j VC]. Thus "monster" was rendered [majos] and [mejan] and "tiger" was constructed as [tajak] and [tajan]. Macken (1993) reports that other children tend to use a glottal stop as a medial consonant. Some languages such as West Greenlandic (Rischel, 1974) have a set of consonants [j,l,v, r] which cannot occur word initially or word finally. In

Winnebago (Hayes, 1995), a set of medial consonants [h,w,n,r] triggers a vowel harmony process by which these consonants end in an intervocalic position. In Spanish the flap [r] behaves like a medial consonant since it is not found word initially or word finally and always occurs surrounded by [-cons] sounds even when it is preceded by a tautosyllabic consonant (García-Bellido, 1999).

I will argue that in Spanish there is a medial consonant [j] which occurs in, for example, verbal and possessive roots. This medial consonant depends on the surrounding presence of two nuclei.

Medial palatals in Spanish come from different historical sources. One is the weakening of an intervocalic consonant FUGENT > [ujen] (Menéndez Pidal, 1968, §113.3), Penny (1991) §2.5.3.2). In other cases, the medial consonant appears to connect two nuclei TUUS > [tujo] (Menéndez Pidal, 1968, § 96; Penny, 1991: §3.5.2). In some Spanish speech varieties this medial consonant has been used with [e-a] environments: pel [ea] “fight” (Castilian speech) / pelleja] “fight’ (Astorga speech) (Menéndez Pidal, 1968, §69).

It is claimed here that this medial consonant [j] in Modern Spanish is affected by VPS as shown in (8).

(8a) Verbal paradigm

V	C	V	V	C	V	C
u	[j]+	o	u	+	[i]	r
“flee 1 st Sg Pres Ind			“flee Inf”			

(8b) Possessive paradigm

C	V	C	V	C	V	C	V
t	u	[j]+	a	m	[i]	+	a
“yours”				“mine”			

In standard Autosegmental theory a medial consonant is a melody shared by two prosodic categories (multi-linked node). This is theoretically accepted because in Autosegmental theory the relationship between members of two adjacent layers is not restricted to be as (9a), as shown in (9) (Goldsmith, 1976).

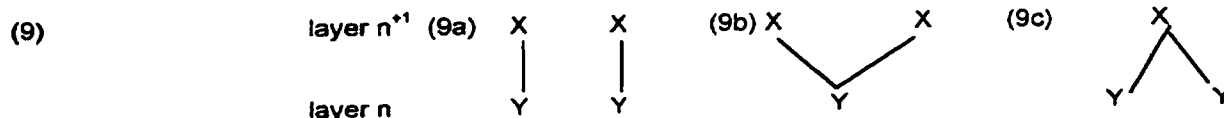

Thus structures such as (9b) and (9c) are not distinct from each other when generalised in one simple definition: One member of one layer is shared by two members of the adjacent layer. The shared element in (9b) is Y while the shared element in (9c) is X. Not surprisingly, (9b) and (9c) have been used in standard Autosegmental theory to account for different phonological processes. Combinatorial processes such as ambisyllabicity (Kahn, 1976) and gemination (McCarthy, 1979) use (9b) where Y in layer n is shared by two Xs in another layer (10). Contour tones (Goldsmith, 1976), bimoric syllables (Hayes, 1989), Syllable template formation (Levin, 1985) can be accommodated in (9c) if X in n+1 shares two Ys in n. Operational processes such as harmony processes (Goldsmith, 1976; Halle, 1995) may use (9b), if for instance, the category [+High], Y in n, is shared by two Dorsal categories X in layer n+1. Thus, autosegmental theory uses multi-linked structures for both combinatorial and operational processes. However, the representation offered for a medial consonant in (10) is not theoretically consistent.

(10)

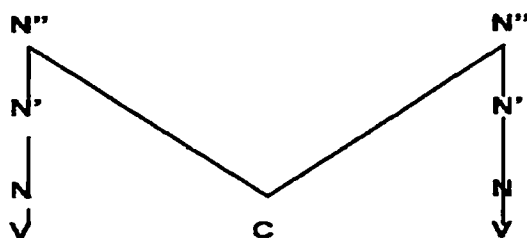

In prosodic Phonology (Selkirk, 1984; Nespor and Vogel, 1986 §1.2. p 13), (10) violates the Strict Layer Hypothesis (SLH) in two accounts. Firstly, C, Y in (9b), is not exhaustively contained in either the first N'' or the second N'' , as is Y in the Xs in (9a). Secondly, (10) violates SLH because C is not the immediate lower category in the next layer down of N'' . To accommodate medial consonants, Prosodic Theory has then two options either to say that segments are not part of its prosodic hierarchy or give up the S L H. If it chooses the former, as opted in Nespor and Vogel (1986, §1.2:14, then Prosodic Phonology is theoretically useless since it is constructed on a vacuum with a lack of segmental content. If Prosodic Phonology allows for (9b), that is (10), then there is no way to stop two N'' s from being associated to one N' , or viceversa one N'' associated to two N 's. Thus Prosodic Phonology with the SLH is too strong because it cannot accommodate medial consonants and Multi-linked Autosegmental theory too weak because it can allow for many different types of associations at any level of complexity.

Furthermore, it is precisely the basic autosegmental concept captured in (9b) which has been claimed to block phonological operations. The Inalterability Principle (IP) (Hayes, 1986; Sheine and Steriade, 1986) predicts that multi-linked categories, Y in (9b), cannot be altered by a rule which mentions C and V in (10). Consequently, C in (10) will not be affected by any phonological process since C in (10) is formally indistinct from a geminate melody. Since C in (4a) is affected by a process which mentions VC, then either VPS is a counter-example to the IP or (10) is not the right configurational representation for medial consonants.

We must conclude that either medial consonants are multi-linked and they are alterable, but we then have to give up the Inalterability Principle, or else medial consonants are not multi-linked. However, if they are not multi-linked, then there is nothing in current phonological theories which allows us to preserve the medial nature of this consonant.

Summarising, the empirical data provided by VPS cannot be accommodated in a standard syllable geometry, multi-linked autosegmental theory or Prosodic theory.

4.1. A SEGMENTAL PHRASE NESTING APPROACH. MEDIAL CATEGORY: THE COMPLEMENT CONSTRUCTION

I will suggest that the problems encountered in a standard phonological approach can be dispensed with if we allow for the notion of segmental Phrase nesting (García-Bellido, 1996, 1997a, 1999; see this recursive concept applied to other languages: Smith, 1999, 2000). This segmental Phrase nesting hypothesis allows for categories A and B in (11a) to nest in each other as in (11b) once A and B are given a Phrase status. This suggestion follows the Linear Correspondence Axiom (Kayne 1984) by which linear linguistic strings are mapped into asymmetric relations (11b) rather than symmetric ones (11a). In (11a) A and B have a symmetric relation because they c-command each other, while in (11b) A and B are in an asymmetric relation because A c-commands B, but B does not c-command A.

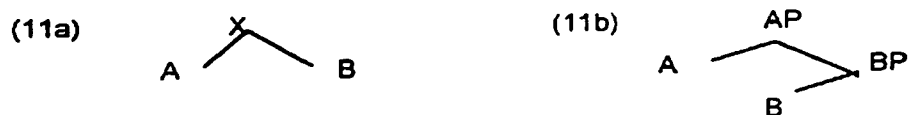

Following this nesting hypothesis, a medial consonant can be thought of as holding a complement relation with the previous and the following

nucleus through its Phrase Category. In (12a) the category T [Time] has been nested. Capital letters are used to denote variables ranging over phonological categories. Their values are given in (11b).

- | | | | |
|-------|-------------------|--------------------|------------------------|
| (11b) | Y=[-cons] = {G,V} | V=[-cons,+voc]={V} | U=[X,Y]={all segments} |
| | Z=[-voc]={C,G} | G=[-cons,-voc]={G} | |
| | W=[+voc]={V,L} | L=[+cons,+voc]={L} | |
| | X=[+cons]={C,L} | C=[+cons,-voc]={C} | |

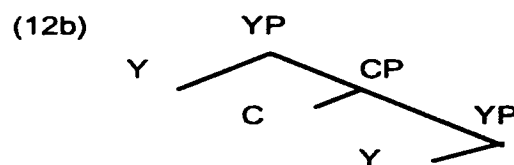
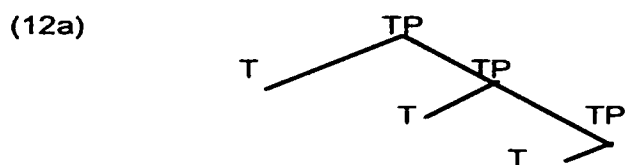

The binuclear structure in (12b) if Y=V, predicts that any voiced palatal sound in any Y, will be holding a complement relation with C and therefore would affect equally C. This nesting hypothesis allows for glides, members of Y, to hold in (13a,b) the same complement relation with C as C holds with the previous V.

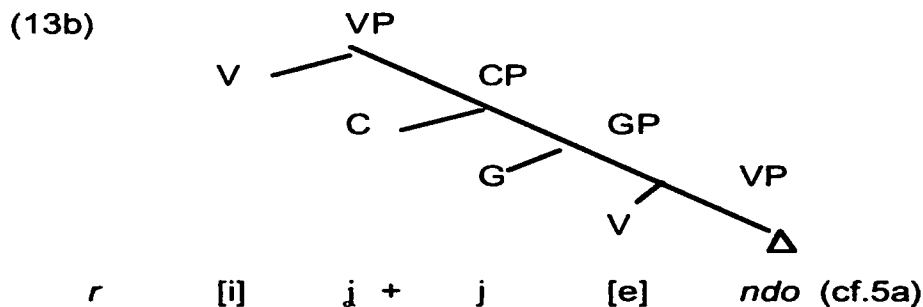
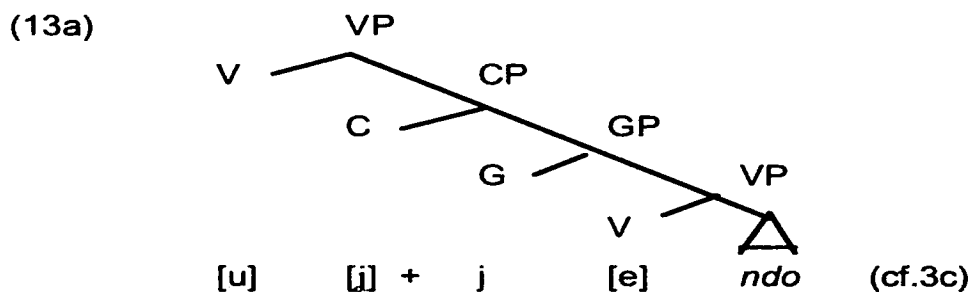

The presence of the middle consonant in the root of *reir* “laugh” in (13b) bears some discussion. This consonant has to be posited in order

to account for the different behaviour that this verb displays when contrasted with the verb *creer* “believe”. The gerund morpheme for 2nd and 3rd conjugation roots is +[j]endo. The verb *creer* is a 2nd Conj root and *reir* is a 3rd Conj root.

(14a) V + G V -> V C V
 cr e + j e ndo cr [e] [j] [e] ndo

(14b) V + G V V C V
 r i + j e ndo *r [i] +[j] [e] ndo

(14c) V C + G V -> V V
 r i j + j e ndo r [i] [e] ndo

If the root “laugh” in (14b) were to end in vowel, like the root of “believe” (14a), we would expect the palatal to be preserved as shown on the right handside in (14b). Since this is not the case, by postulating a medial Voic.Pal. consonant in the root of “laugh” (14c), and by having VPS, we get the expected result (14c). It will be shown that VPS as analysed here will account for the simplification of the two palatals in (13b). The verb “laugh” is subject to a height dissimilation process whereby the root vowel is [i] or [e] depending on the height of the following desinence vowel (García-Bellido, 1986). The medial consonant j then never has a chance to surface phonetically as [j] because it is always subject to simplification triggered by the presence of a voiced palatal vowel in the root or the desinence (Cf. 13b,14e).

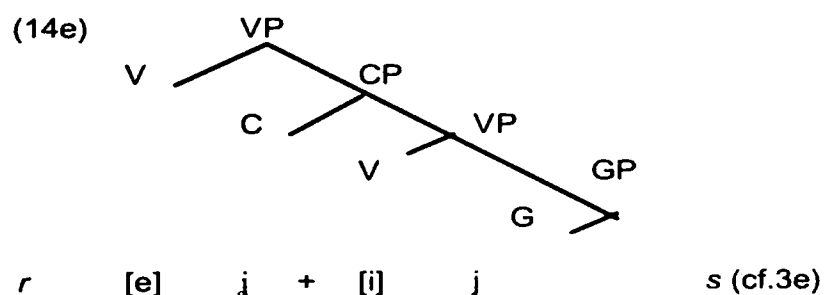

In order to understand why the Glide of a Gerund is not present when the root of the verb is a Vowel (14a), I will suggest that in Spanish there is a set of combinatorial dependencies which can be encapsulated in the following algorithm (14f) with which the G of a Gerund is associated.

(14f) Voiced Palatal: Down or Up algorithm.

- (i) (20b) or (20d)
- (ii) Otherwise (20a)
- (iii) Otherwise V

This algorithm is associated with, for instance, the conjunction “and” in Spanish (14g). The algorithm searches to combine first with one lower vowel, otherwise with one upper vowel (mononuclear connector) (14f.i,ii), if it fails then it is a vowel (Receptor) (14f.iii). Thus, if a Vowel is found on the lower site, then the algorithm searches out a consonant X (cf. 11b) on the higher site (14g.1, cf. 20d). If it does not find a consonant on the higher site, the algorithm projects an adjoined C, j, (14g.2 cf. 20b), in the higher site. If (20f) were in (14 f.i), then the conjunction would be incorrectly simplified in contexts such as * *pi l [i] j [a] lberto* “Pili and Alberto”. If it does not find a vowel on the lower site, it searches out a vowel on the higher site. If it finds it, it is a postvocalic Glide (14g.3 cf. 20a); if it does not find it, it then ends producing a Vowel (14g.4).

(14g)

- | | | | | |
|----|-------------------------------------|-------|-----|--------------------------------|
| 1. | <i>mart a [s] [j] [a] lbertos</i> | (20d) | CGV | “ <i>Martas and Albertos</i> ” |
| 2. | <i>mart [a] [j] j [a] lberto</i> | (20b) | CGV | “ <i>Marta and Alberto</i> ” |
| 3. | <i>mart [a] [j] [p]edro</i> | (20a) | VG | “ <i>Marta and Pedro</i> ” |
| 4. | <i>martas [s] [i] [p]edros</i> | | V | “ <i>Martas and Pedros</i> ” |

In (14g.2) VPS simplifies the glide as in the example given in (6a).⁴

The nesting hypothesis together with the hypothesis that VPS only applies if its members are locally connected in a c-command relation, explains why two possible outcomes are found in Spanish.

In (15a) and (14f.ii) VPS cannot apply because G cannot c-command the second V. The first word is adjoined to the second word. In (15b) and (14f.i: 20b), VPS can apply because G and G c-commands V and is C-commanded by CP. The first word is not adjoined to the second word.

(15a)

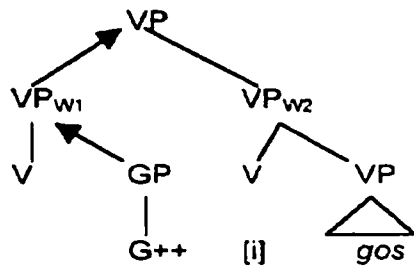

[a] [i] "there are figues"

(15b)

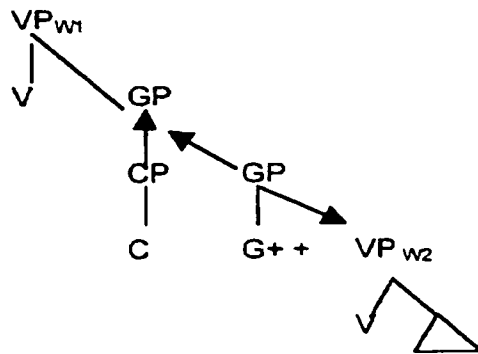

[a] [i] j [i] gos "there are figues"

If medial consonants need to be nested in a previous nucleus, voiced palatal initial consonants do not. The voiced palatal in a word like [jip] "Jeep" in (16b) cannot hold the same relation with the following nucleus as the middle consonant does in (16a). If it did, then we would predict that VPS would simplify the consonant in (16b), in the same way it does in (16a), yielding incorrectly *[ip].

(16a)

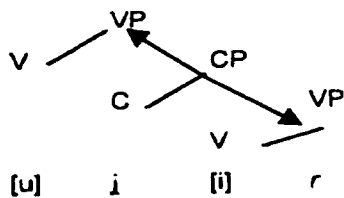

(16b)

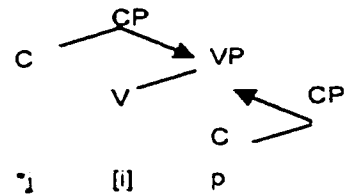

The fact that the voiced palatal consonant is preserved in [jip], needs to be explained.

4. 2. INITIAL CONSONANT: THE ADJUNCT CONSTRUCTION

I will suggest here that the palatal consonant in [jip] is adjoined to the lower YP nucleus. If VPS is sensitive to hierarchical properties, then the fact that some prevocalic consonants are simplified and others are not may derive from the hypothesis that prenuclear voiced palatal consonants may hold two totally different relations with their lower YP Nuclei.

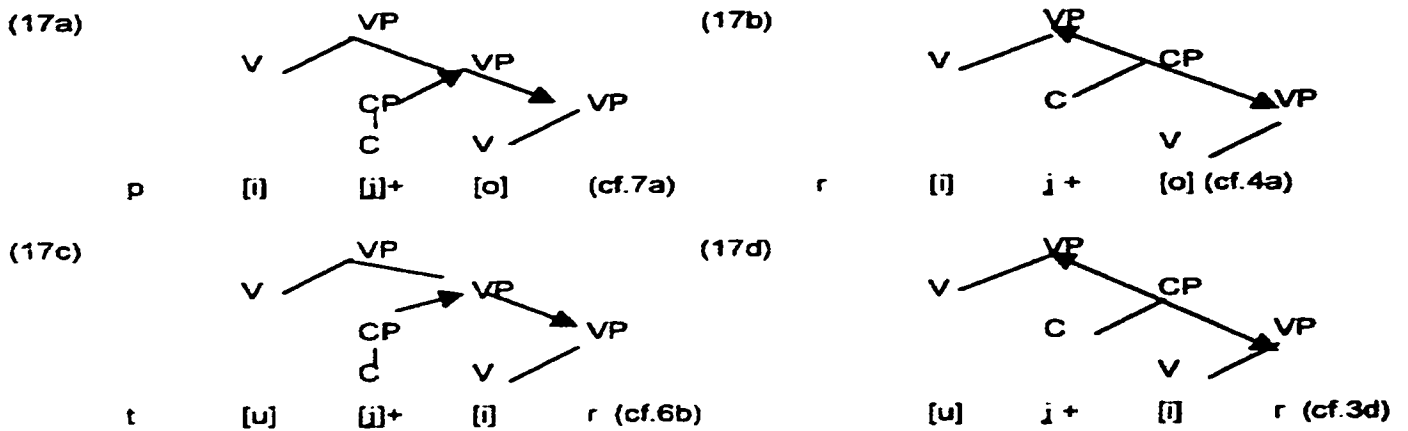

Medial consonants in (17b,d) hold a complement relation with the lower YP Nucleus (20f), while initial consonants in (17a,c) hold an adjunction relation with the lower YP Nucleus (20c,20b). However from this hierarchical difference there is so far no understanding as to why one is immune to simplification and the other is not.

4. 3. MOVEMENT-TRACE THEORY AND ISLANDS

Syntactic research within a movement-trace framework has advanced a plausible hypothesis to account for movement asymmetries. While categories seem to move out of structures which hold a complement relation with a head, as YP shows in (18a), elements which are inside a structure which does not hold a complement relation with a head, as YP shows in (18b), seem to be unable to connect outside the adjoined YP and are therefore trapped inside an island. For instance elements inside adjoined structures are incapable of movement (Huang, 1982; Manzinni, 1992). Here variables are not ranging over phonological categories but syntactic ones. Their values are irrelevant here and do not affect the argument.

(18a)

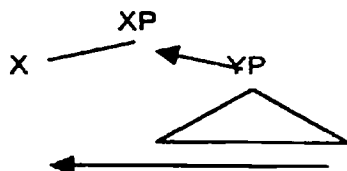

Who_i do you _{XP} [_x [believe] _{YP} [Mary loves t_i]]
 A quién _{XP} [_x [crees] _{YP} [que Maria ama t_i]]

(18b)

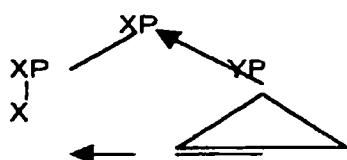

*Who_i do you believe _{XP} [_{XP} [_x [the fact]]] _{YP} [that Mary loves t_i]]
 * A quién_i crees _{XP} [_{XP} [_x [el hecho]]] _{YP} [de que Maria ama t_i]]

If VPS is thought of as an operation whereby the head of a complement CP, C in (19a), moves to adjoin to the head of VP as in (19b) and under identity the moved element is deleted, then the fact that the C in (17c), for example, is immune to simplification may derive from the assumption that C in (17c) is inside an adjoined construction and cannot move out of the island.

(19a)

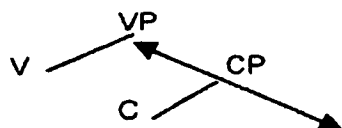

(19b)

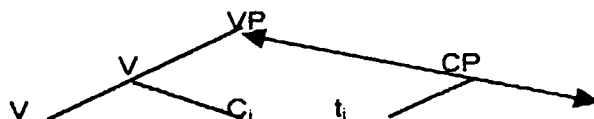

Following this reasoning, a mononuclear consonant, (20c), in the examples under (6a,b;7a,c,d) will not move out of the adjoined structure and therefore will not be able to be simplified, as illustrated in (17a,c). The same logic leads us to assume that any voiced palatal in a head complement relation will be able to move and therefore be simplified. So in (17b,d) the consonant moves out of a complement Phrase and is simplified.

The assumption that voiced palatal prosodic heads move out of a complement phrase does not explain why consonants and glides are simplified but vowels are not (Cf. 2a and 3a,d,e, 4a, 5a, 6b, 7a, 15b, and 17 and the examples under 3a,b,d,e, 4a, 5a, 6b, 7a, 15b, 16b, and 17, above).

4.4. COMBINATORIAL DEPENDENCIES: CATEGORIAL AND ORIENTATION DEPENDENCIES

I will suggest here that voiced palatals move if they are dependent in the prosodic structure. In Spanish only Vowels are independent +I since only they may occur by themselves in an utterance. Thus questions in an utterance may be just one vowel: [a] “where to?”, [i] “and?” [o] “or?” etc. Thus, this assumption predicts that a non-adjoined voiced palatal Z={G,C} will move because it is dependent -I (Connector) while a palatal Vowel will not, because it is not dependent (Receptor) (cf. G in (3a); G in (3b); C in (3d); C and G in (3e); C in (4a); and G in (6a)).

I will sketch very briefly the set of different dependencies, that Glides and Consonants may have in Spanish (García-Bellido, 1999). The categorial and orientation dependencies associated with segments are the building force of hierarchical structure since hierarchical well-formedness is derived from them.

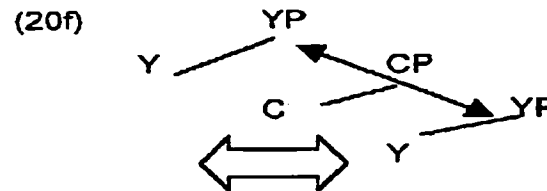
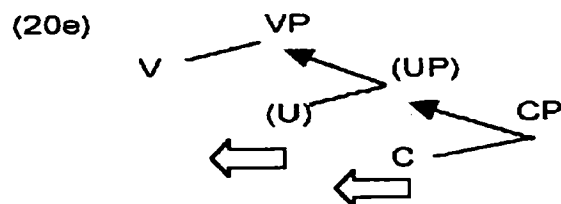
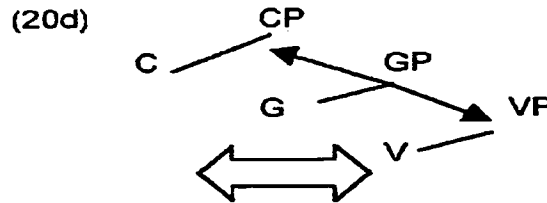
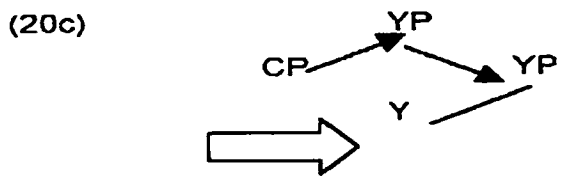
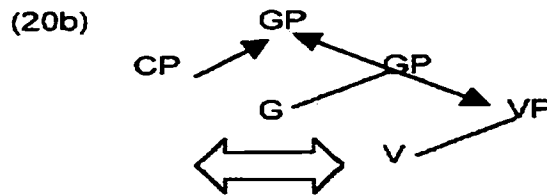
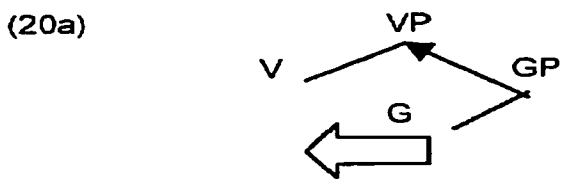

In (20) an arrow under a category indicates that this- category has associated with it a combinatorial and orientation searching algorithm which uses hierarchical orientation {higher, lower and, higher and lower}. This is equivalent to a subcategorisation frame.

The fact that a segment may be associated with a categorial dependency does not guarantee that it may connect on the right side. Thus (20g) is impossible because the combinatorial categorial dependency of Z:V and the combinatorial orientation dependency of Z: lower, are not satisfied. In (20g) Z depends on a lower V but Z is not connected to a lower V. Only in (20h) the combinatorial conditions of Z are met: the category and the orientation dependency are met by the connection of the lower V with Z. ⁵

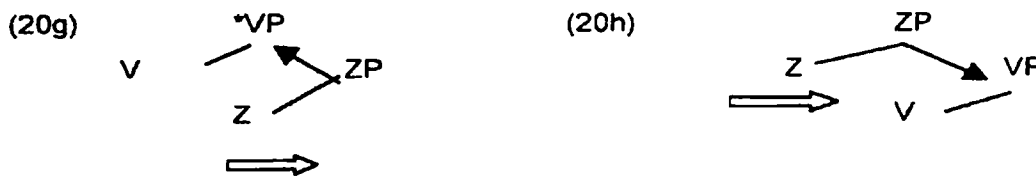

We have shown that in Spanish there are three different [j]. First, an initial consonant [j] in (20b) derived by algorithm (14f.i). Secondly, a mononuclear initial consonant [j], (20c), found in (17a,c). Thirdly a binuclear medial consonant [j], (20f), found in (17b,d). The first two are immune to simplification because it is assumed here that their heads cannot move out of an adjoined structure. The third one is subject to simplification because its head can move out of its complement structure. Postvocalic Glides (14f.ii), liquids and obstruents arise when their combinatorial condition: $V \Leftarrow$ connects them directly to a preceding vowel. Thus, G is connected to V in # [a][j] (15a)(20a); but [a][l]; [a][r]; [a][b] etc, X in (20e), are cases of direct connection of X to V. Mononuclear nasals may be associated with a combinatorial dependency which connects them directly or indirectly to a V: $V(G) \Leftarrow$. Thus, a mononuclear nasal, derived from the algorithm given in (29), can occupy X in (20e) provided that $U = G$ [a][n]; [e][j][n]. Finally in all Spanish varieties which have [h] (see footnote 3), [h] is associated to a combinatorial dependency which connects it directly or indirectly to V: $V(U) \Leftarrow$. [h] can occupy X in (20e) provided that U does not include V. The algorithm of a binuclear X (20f), requires a higher Y to C-command X and a lower Y to be the complement of X.

Under this approach, prosodic structure is derived from the success of the combinatorial dependencies of its members. The combinatorial approach assumed here is therefore superior to the template approach

used in standard autosegmental theory since it captures the local properties of VPS. It also captures the local requirements of mononuclear connectors and binuclear connectors.

If non-adjoined consonants and glides are simplified because they move, then so far nothing explains why G in (21a, cf. 7c) does not simplify, while G in (21b) does. In (21) we know that the C of the adjoined CP cannot move, therefore we predict correctly that in (21b) only G moves and deletes. However, the same assumption fails in (21a).

(21a)

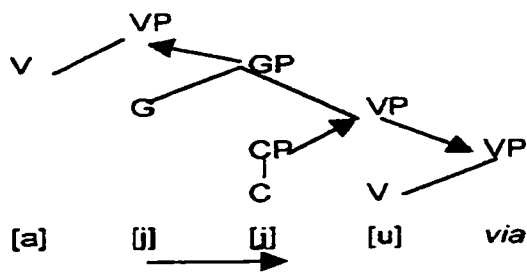

(21b)

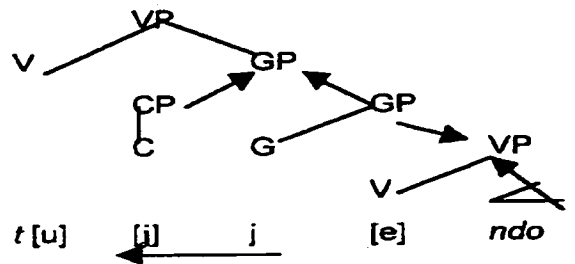

4.5. OPERATIONAL DEPENDENCIES

I will suggest that the empirical fact observed in (21) derives from a general asymmetry, governed by both the type of voiced palatal {Receptor +I, Connector -I} and the hierarchical relation that each voiced palatal holds with the other in a sequence.

(22) Head Movement Asymmetry in VPS

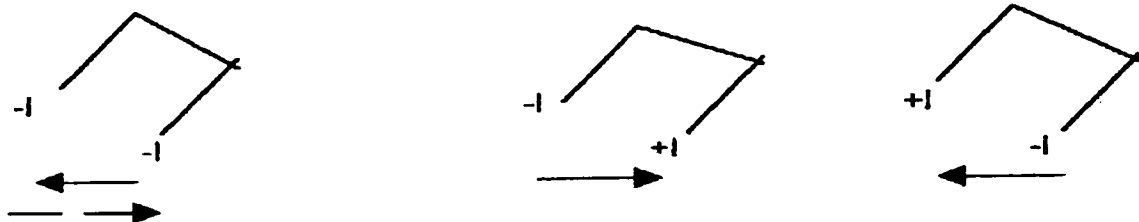

In (22) a voiced palatal connector may connect with a voiced palatal receptor and undergo VPS regardless of the hierarchical relation that each holds with the other. A medial voiced palatal consonant will be simplified in contact with a voiced palatal vowel which is higher or lower. In (17b) VPS simplifies the medial consonant when the vowel is higher and in (17d) when the vowel is lower. These findings suggest that if VPS is analysed as a movement-trace operation then the trace is not c-commanded when the connector is c-commanding the receptor. However,

the operational freedom found in a receptor-connector match is restricted when two connectors enter into the process. In such a case, only the upward movement triggers simplification (cf. 21b). This latter case fits the movement-trace theory (Chomsky, 1981,1995) since this theory predicts that if the higher connector moves downwards then the trace is not c-commanded. If the interconnector movement in (22) were downwards we would predict incorrectly that the G in (21a) would be simplified producing *[a][j][u]via, we would also predict that both the middle consonant and the glide would be simplified *[u][e]ndo in (13a). However the restriction in (22) must be correct since G is not simplified in (21a) and in (13a) only one connector is simplified. Therefore the asymmetry prediction of the movement-trace theory is empirically supported between connectors but not between connectors and receptors.

One advantage of the movement-trace theory is that VPS does not need to be restricted to any linguistically extrinsic constraint (García-Bellido, 1999). In (13b) the Phonetic Form (PF) of G may move to C and check its identity with the Non-Phonetic Form (NPF) copy left behind by C. Under this approach there is no need to constrain Spanish to be parsed leftwards, as suggested in Itô (1989); there is no need to constrain Spanish to apply processes cyclically (cf. Cole, 1995 for a discussion on the problems of cyclicity) nor to restrict the application of VPS to be extrinsically ordered to get good results.

While the generalisation in (22) seems to make the right empirical predictions, there is no explanation so far for why VPS, which is not a segmental process, may not apply at a distance as other harmony processes do.

It is well documented that children apply consonantal harmony and vowel harmony in their first stages of development (Menn and Stoel-Gammon, 1995). Thus “duck” is rendered [glu[k], involving a Place of Articulation (velar) harmony process, and “monster” is rendered [tajak], involving a two identical nuclei harmony operation. Consonantal and Vowel harmonies are also used by many adult languages including game languages (Van der Hulst and van de Weijer, 1995). If connections are produced at a distance, then there is nothing so far which prevents G in (23a) from moving directly to C as it does in (23b).

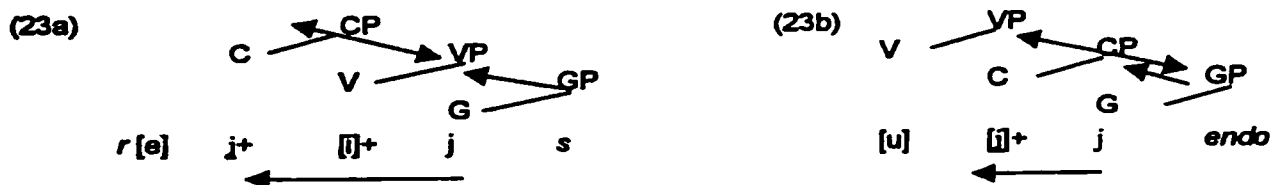

In (23) G moves apparently to C in a -I -I domain in both examples. Following the same freedom we expect G to be simplified in (24). However this expectation is not empirically supported since [u][j][a][j]s but not

(24)

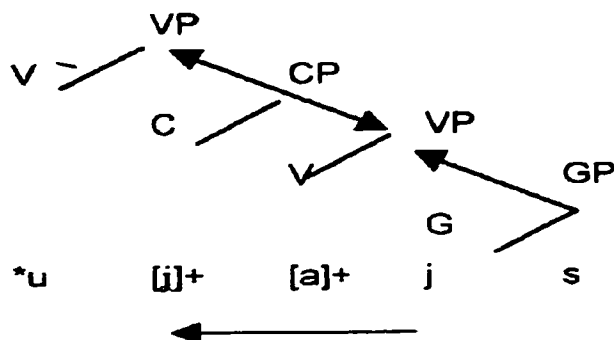

4. 5.1. RELATIVIZED MINIMALITY

I will suggest here that VPS is constrained by a non-crossing operational principle used independently in Autosegmental Phonology (Goldsmith, 1976) and in Syntax (Rizzi, 1990). In particular a relativized non-crossing principle says that a process may not skip a potential site of operation, i.e a target site. Thus a child may skip a vowel in a consonantal harmony process because the target of the operation is set to look for a consonantal site only (selective or relativized search). So, vowels are transparent in a selective consonantal search. In the same way in a Consonant harmony process, vowels are transparent because the search is set to look for consonantal sites where to operate.

I will show that VPS is subject to the same selective operational constraint. Since VPS is an operation whose landing targets are V and C and G, then no V, C, or G will be skipped in the operation. Thus in (24) if the search is set to select U = {X,Y}, [-cons] sites and [+cons] sites, then the first V will be a potential site of operation. Since the V in (24) does not have a voiced palatal, then the search is unsuccessful.

4.6. MATCHING AND THE MESSENGER HYPOTHESIS

Whether the Glide actually moves to check, or something inside the G does, needs some discussion. Suppose G moves in (24), then we expect that since G has attached to the head of V and no voiced palatal identity has been found, then G will not be deleted. This movement will create a complex prosodic head indistinguishable from its initial state. However this logic will predict that since a voiced palatal moves blindly

in any direction, as (22) shows, it may move to the wrong place and miss the palatal. Thus in (16a) nothing stops the medial consonant from starting the search going upwards and landing in the head of the higher V. Once there, it will not be deleted since identity has not been found, producing an incorrect empirical result *[u] [j] [i] r. Under the movement-trace hypothesis, we will have derivations, such as the one just discussed, which will have to be made to crash under some unknown general principle.

A way out of this may be to view VPS as two independent processes: the search for a match and the simplification process. Suppose that every voiced palatal connector -I has two Messengers M associated with it (25). One M is specialised in going up (UM) and another M in going down (DM). M has the property of searching for a specific set of features, here voicing and palatality ($_{VP} M$). M has also the property of recognising a VP match. M has also the property of stopping the search on the first U, since its site includes everything which is consonantal and everything which is not consonantal (M^U).

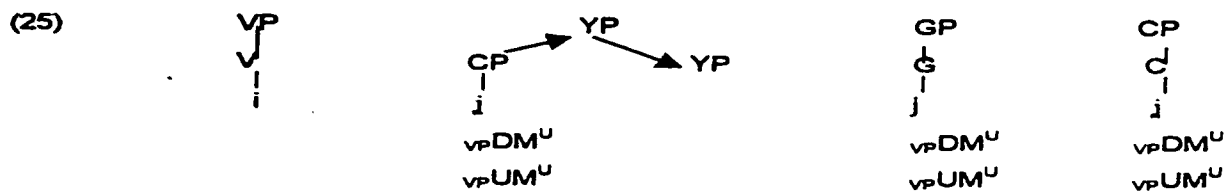

This match must be a sufficient condition for simplification, since we find simplification if a $_{VP} M^U$ has been able to match the VP but not if a $_{VP} M^U$ has not been able to match it. Thus a sequence of two VP vowels or one single VP vowel will not be simplified since the VP recognition has not even been initiated and therefore has not taken place (cf. 7b). A sequence of a VP and a non VP will not be subject to simplification, since $_{VP} M^U$ will have been unable to successfully match its VP (cf. 24). There will be no simplification either in cases where a $_{VP} M^U$ is unable to get out of an adjoined structure (cf. 17a,c).

A theoretical advantage of this approach is that if a messenger does not find a match, the derivation is preserved, while in a PF- movement-trace theory the derivation will have to be made to crash by some unknown principle. Moreover a PF-movement-trace theory will have no explanation for why if a medial palatal consonant that is never heard in the language may move, (cf. the case of the verb “laugh” in Spanish (13b)). Under this approach elements in PF do not need to move. Instead the element which moves, is not a sound matcher sound but a messenger which is an abstract feature recogniser in a Non Phonetic form (NPF). Thus a child who learns the paradigm of the verb “laugh” will not have any acoustic

or articulatory input to be able to assume which Phonetic Form the medial consonant has in its root. Under this approach the child's language system only knows that if the verb "laugh" in Spanish has implicitly a voiced palatal medial consonant at the end of its morphological root with messengers which search selectively to match voiced palatality, then a series of linguistic explicit sequences are heard and articulated.

While matching is a sufficient condition for simplification, matching is not a necessary condition for simplification. Thus, if $_{VP} DM^U$ finds a match in another connector then simplification is not produced (cf. 21a). In movement-trace theory the lack of simplification in this context is ruled out by a general principle which "forces" traces to be c-commanded by their antecedents. In (21a), if the Glide moves to match with the VP Consonant, then its trace will not be c-commanded by the VP Consonant. However this general principle, as we have shown cannot be invoked here because it fails to predict simplification in connector-receptor cases (cf. 22).

4.6.1. THE INHIBITORY HYPOTHESIS

Recent research in cognitive approaches to language production has advanced the hypothesis that speakers may be using specific mechanisms to select the items which are produced in language. One model, assumes that once one common feature has been found in two linguistic items, both are activated. An inhibitor process inhibits or dampens the activation of the not-in-use -item, ensuring that its activation levels are lower than those of the in-use-item (Green, 1998, Poulisse, 1997 but see Costa and Caramazza, 1999). Following this model, it can be suggested that the findings presented here with respect to the behaviour of VPs, lend support to the hypothesis that an inhibitory process selects specific VPs lowering their activation levels once they have matched. The findings discussed here allow us to capture the generalisation that the inhibitory process only lowers the activation levels of some items which have initiated a successful match. If we assume that a $_{VP} DM^U$ in the match of two connectors does not flag its successful match, and the inhibitory process only inhibits flagged items, then the inhibitory process will fail to inhibit the unflagged match. Furthermore if we assume that the matching produces the activation of a transcription from a NPF information to a PF one, then the eventual articulation of VPs will only select those whose PF is available but will correctly exclude those which have not been transcribed into PF. All the remaining cases of unmatched VP segments will have their automatic transcription which will be available for production.

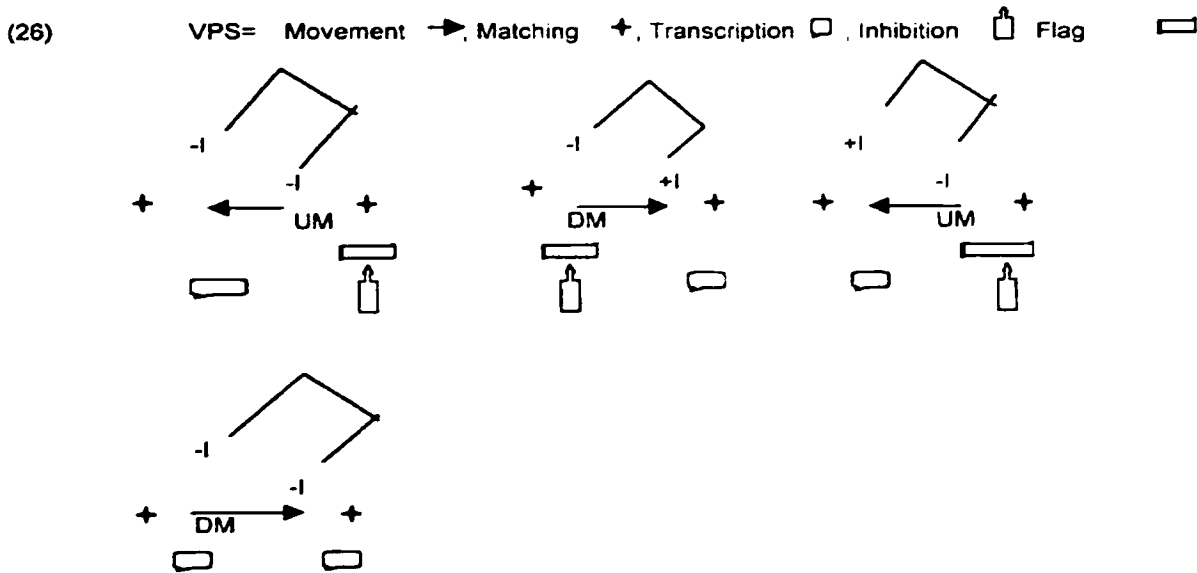

Since the inhibitory process only targets flagged items, we predict that cases like (13a) where a ${}_{VP}UM^I$ has flagged G but a ${}_{VP}DM^I$ has not flagged G, will correctly target G for inhibition but not C.

If the inhibitory process lowers the levels of activation of a fired transcription, we expect alterations in the connections of surrounding elements which will activate their combinatorial algorithms to connect in the sequence. The activation of combinatorial algorithms which allows segments to combine with others may be subject to further inhibitions. This is reflected in the following three examples given in (27a,d,e)

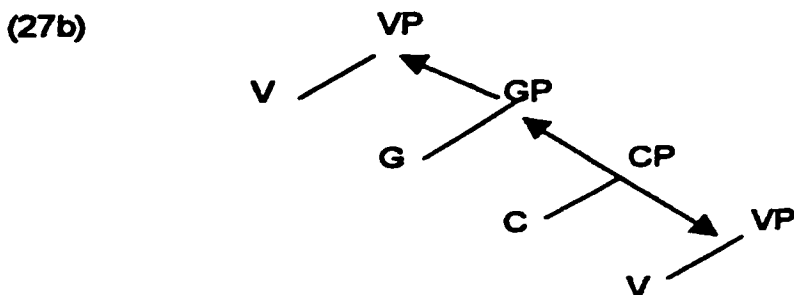
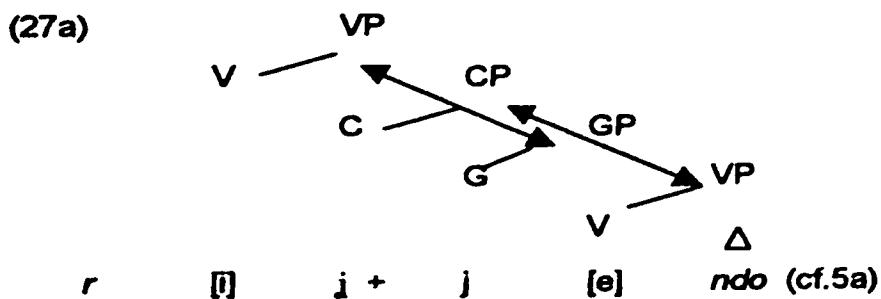

- (27c) [o] [j] [g] + [o] "I hear Pres"
- (27d) [o] [j]j j + [e] s "you hear Pres"
- (27e) [o] j[~] j + [i] mos "we hear Pres"

In (27a) G is inhibited when the combinatorial algorithm of C and G are satisfied and C and G connect. C is inhibited when V and G successfully combine. In (27b) the verb has a process whereby the medial consonant agrees in backness with the following vowel of the desinence. This process shows a velar consonant in (27c) and a palatal consonant in (27d,e). In (27d) only the medial consonant is inhibited when combining with the upper and lower nuclei, and matching with the upper G, following (26). The algorithm in (14f.i) combines G with the lower V in the sequence, triggering (20b) which triggers a further inhibitory process affecting G. Finally, in (27e) when the medial consonant combines with the lower and upper nucleus, it matches with the lower V and is inhibited. The algorithm of G combines G with the lower V in the sequence, triggering the damping of G. The morphological point of connection seems to be affected by the inhibitory process when both morphemes connect. Once that point is resolved, the activation of C is dampened. Thus, in *oj j+j endo* "hear +Gerund", the activation of the lower G is dampened when both morphemes connect and C's activation levels are lowered making the algorithm of the upper G connect this G with the lower V and project [j], as in (27d), making G become dampened: [o][j]j j +j [e] ndo. If the activation of C were dampened when connecting with the upper G, we would expect: *[o][j][j] j+endo. Under our approach this latter outcome is impossible since C is uninterpretable unless it connects with both nuclei. In all cases the fall of activation of C is not sufficient to stop the connection of G with V (27e).

However this approach so far predicts that in a case such as *jard [i] [ŋ] [j]eno* "garden full" there will be two contradictory inhibitory operations and therefore there are two possible outcomes. While the nasal assimilation process in Spanish creates a palatal articulation in a postvocalic site (7d, 28), VPS predicts so far that the articulation of the nasal palatal will be inhibited (cf. 26) because the nasal palatal is -I and its UM matches in

+I. Furthermore VPS also predicts that the nasal palatal will not be inhibited because its DM matches in the following consonant but the inhibitory process will not target the palatal nasal (cf. 7d). Thus we expect

the nasal to be present or not depending on which VPS wins. However in all dialects the nasal is always articulated as shown in (28a) (cf. 2).

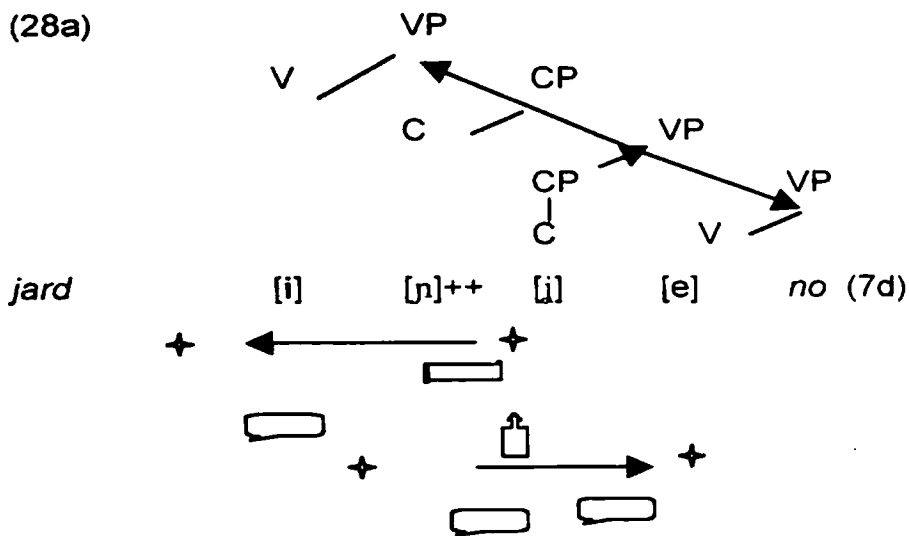

4.6.2. NAŠAL ASSIMILATION AND VPS

In Spanish when a nasal does not assimilate to the PA of a following consonant, then a default articulation is found. In some speech varieties, such as Castilian, an alveolar [n] is found: p[al][n] “bread”. In other speech varieties, such as Andalusian and Caribbean Spanish, a velar is found instead [ŋ] (Zamora Vicente, 1985; Canfield, 1981; Harris, 1984). Nasals do not seem to assimilate to the PA of a following nasal: [i] [ɲ] [m] [e]nso “immense”. Under this approach nasal assimilation operates only in a c-command domain. Thus two possible outcomes are correctly predicted in Caribbean Spanish depending on whether the nasal c-commands the lower consonant, as in (28a), or not, as in (28b) (García-Bellido, 1999).

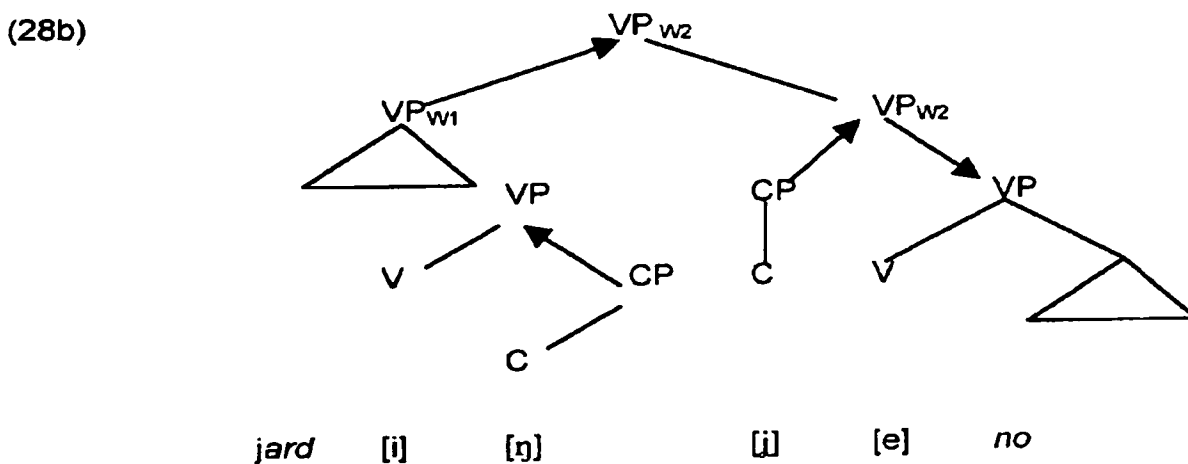

Nasal consonants have a combinatorial algorithm as shown in (29). A nasal is a mononuclear connector. Its algorithm combines it with a lower nucleus (G)V in its word $\{[m],[n],[\eta]\}$, if it does not find it, it combines it with an upper nucleus V (G) in its word. In this latter case the nasal assimilates the place of articulation of the following non-nasal consonant. If there is none, then the nasal transcribes the default PA.

(29) Nasal algorithm

1. (20c)
2. Otherwise (20e) and PA assimilation
3. If no PA assimilation then Default PA

In (28a) the nasal has failed to apply (29.1) but has combined with a higher nucleus. Because there is a non-nasal consonant from which to assimilate, then PA assimilation takes place (29.2). Therefore (29.3) does not apply. In (28b) the nasal has combined with a higher nucleus but has failed to find a consonant with which to assimilate since the consonant is not in a c-command domain. Therefore the default PA is predicted.

What concerns us here is whether the nasal has a VP messenger. The nasal in (28a) cannot have any VP messengers, because its Palatality is not bound to Voicing in one single messenger $_{VP}M^U$ (Cf. 30b) as it is in all the cases we have discussed previously (30a). The Palatality of the nasal is bound to a messenger which searches for PA in a lower non-nasal consonant $_{PA}DM^{-NC}$. We assume that Voicing in the nasal cannot bind to $_{PA}DM^{-NC}$ and form $_{VP}M^U$ (Cf. 30c). Therefore if the voicing of the nasal cannot bind with another M in one single M, then there is only one $_{VP}M^U$ in the palatal sequence of (28): in the adjoined CP. If this is correct, then the nasal palatal, which does not have a $_{VP}M^U$ will never be able to match with the VP vowel or the VP consonant.

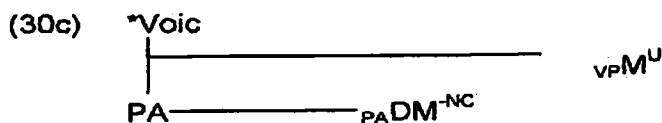
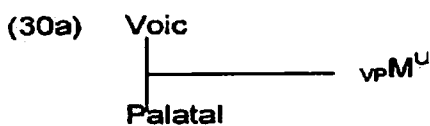

The binding of the PA in the nasal requires some clarification under this approach. It is assumed here that the nasal has a Messenger which

searches for a PA in the lower non-nasal consonant $_{PA}DM^{NC}$ by virtue of combining with a higher nucleus. If M finds a PA, then the matching which is not flagged according to (26), initiates a transcription which fails to be inhibited. Recall that a DM in a connector domain does not trigger inhibition. Therefore the palatality of the nasal does not interfere with VPS and PA assimilation (here matching (Cf. 29.2)) is correctly predicted not to be inhibited.

5. CONCLUSION AND DISCUSSION

It has been concluded that the current theoretical concept of what a well-formed prosodic structure is, and how structure-dependent phonological processes work, cannot account for VPS (§3). It has been suggested that hierarchy-dependent operational constraints, present independently in the syntax of words, may be responsible for similar effects encountered in VPS. It has been possible to articulate this hypothesis once the categorial and orientation combinatorial dependencies associated with segments have been satisfied in asymmetric hierarchical structures (§4.4). The fact that general principles operating in the Syntax of words are found in other components is not controversial. Most recent work in morphology points in that direction (Baker, 1988; Hale and Keyser, 1993). It is not surprising then that linguistic sound, being part of a general language ability, could also have a syntax of its own.

We have observed that current phonological models analyse VPS as a simplification operation affecting articulations. We have suggested here that VPS is probably better analysed as an inhibitory process which interrupts a mapping from a Non-Phonetic Form (NPF) onto a Phonetic Form (PF) allowing those sites whose activation levels are higher to be selected for production. For the mapping of NPF onto PF a child needs to know how to map information kept in a NPF onto a corresponding potential articulatory form which we call here PF. Presumably for the motor system to be responsive to the activation levels of the PF there must be a voluntary mapping from the PF into the motor areas of sound articulation in the brain. This must be so, because speech is not necessarily articulated: there is silent speech and reading. These mappings are not trivial but this issue does not affect the point we are making here. What we argue is that our analysis predicts when the mapping from NPF to PF in voiced palatals is inhibited and when it is not. If motor articulation is not successful when PF is voluntarily mapped into motor areas of the brain, we assume that it is due to a more peripheral impairment which is

probably outside the central syntactic system of the sounds and outside the scope of this article (Caplan et al., 1999).

The positing of NPF as distinct from PF bears some discussion. Children seem to be understanding language in a way which does not always match their production. Thus a child may show understanding of words which are acoustically formed for her but may not be able to fit them within her production capacities. This may be perhaps because the child has not obtained the correct mapping from a NPF to a PF or because some motor articulatory development in the articulators is still lagging behind (Kent and Miolo, 1995). For instance the [w]abbi for [r]abbi case in English children or the use of flap for trill in Spanish children could be an example of this latter case in developmental stages in articulation. On the other hand if a child says *ʌj|l|mos* "we flee", it may be because she is making this verb to be a member of the class of verbs like *ʌi|j| ar* "catch" which have an adjoined voiced palatal C. This analogical case is very frequent even in second language learners (Pinker, 1994). However if a child says *ʌi|l|o*, *ʌi|l|e|ndo* and *ʌe|l|o*, *ʌe|j|e|ndo* but she never says **ʌi|j|e|ndo* and similar cases, then we must conclude that the child's system is functioning with the processes discussed here which account for VPS. If this is so, the child's system has a medial C which is neither analogical, like the one in *ʌj|l|mos* "we flee", nor acoustic, because there is positive evidence that the voiced palatal medial C is neither heard nor articulated. Then the NPF of the C in this verb is a pure linguistic entity containing as sole information an binuclear combinatorial algorithm as shown in (20f), a Voiced component and a Palatal component associated with a matching M, $\nu_p M^{\downarrow}$, whose up and down copies search for a matching from its head. It remains open what the real nature of these linguistic constructs are in the realm of the physical world.

These findings lend support to models of grammar acquisition (Dresher, 1999) in which learners are not seen as attempting to match target forms but may use them as evidence for developing abstract combinatorial, matching and inhibitory local cues.

Paloma García-Bellido
 University of Oxford
 47 Wellington Square
 Modern Languages Faculty
 Oxford OX1 2JF, U.K.
 e-mail: paloma.garcia-bellido@mod-langs.ox.ac.uk

NOTES

1. Throughout the paper when referring to a Spanish sound I will use the International Phonetic Alphabet (IPA). If it is pronounced in the speech chain I will use squared brackets. A IPA symbol without squared brackets indicates that the potential sound is not pronounced. Standard Spanish spelling will be used in Italics. + indicates morpheme boundary and ++ word boundary. In (1) only VPs which are common to all varieties have been included in the chart (see Harris and Kaisse, 1999 for a feature analysis of palatality). In some speech varieties, such as Argentinian, there is also a voiced prepalatal fricative consonant [ʒ] (Canfield, 1988; Harris and Kaisse, 1999). In other speech varieties, such as Castilian, there is additionally a Lateral [l] (Zamora Vicente, 1985). Earlier drafts of this work were presented at the Phonology of the World's languages symposium (Pezenas, 1996), HILP 3 (Amsterdam, 1997), XXVII Simposio de la Sociedad Española de Lingüística (Palma de Mallorca, 1997), The Romance Linguistics Seminar (University of Oxford, 1998) and the X Conferencia Internacional lingüístico-literaria (Santiago de Cuba, February 2000). I am grateful to these audiences and to Beatrice Clayre, John Coleman, Ellen Kaisse, Jay Keyser, Martin Maiden, Rebecca Posner, Gillian Ramchand, Iggy Roca and Norval Smith for their comments. All mistakes are mine.

2. I simplify matters in the examples. In an autosegmental approach using for instance Halle's 1995 feature geometry the Place and Guttural subsegmental nodes of C or G will have to spread to associate with the Place and Guttural nodes of the next voiced palatal segment in order to be delinked under identity. A delinking of the residual features will have to be eventually performed. This does not affect the argument.

3. This generalisation of course is false if the glottal fricative is allowed to become an Onset consonant as suggested in Harris, 1983. As we will prove in this article, a C in a VCV sequence does not become "automatically" initial. If it did, then medial consonants would not exist in Spanish and other languages; languages like Arrernte (Breen and Pensalfini, 1999) would not exist either. In fact there is no linguistic evidence supporting the claim that a glottal fricative is ever initial in Spanish. In this framework, this falls out from the assumption that the set of combinatorial dependencies which give [h]/[s] are mononuclear and subject to a c-command hierarchical relation, like all combinatorial processes (see discussion §4.4.):

(i) Combinatorial algorithm [h]/[s] for RN (RN data from Harris and Kaisse, 1999)

1. Combine with a lower Nucleus in the same word (20c): [s]: ca[s]+[a] "house" *ve[s] ++[u]no "you see one" de[s]+[a]rmar "to disarm"

2. Otherwise combine with a higher V (U) in the same word (20e): [h]: da[h]l[pl]a "dandruff" v[e]l[h] "you see!"

3. Otherwise project a higher V in the same word (20e): [h]: [e]l[h]f[ɛ]ra "sphere" in++[e]h]table "unstable".

(ii) Combinatorial algorithm [h]/[s] for PO (PO data from Harris and Kaisse, 1999)

1. Combine with a lower Nucleus (20c): [s]: ca[s]+[a] ve[s] ++[u]no de[s]+[a]rmar

2. Otherwise combine with a higher V (U), otherwise project a higher V, in the same word (20e) and with a lower C: [h]: ca[h]l[pl]a v[e]l[h] ++[d]os; V Projection: [e]l[h]f[ɛ]ra [e]l[h] [t] oy "I am"

3. Otherwise combine with a higher V (U), otherwise project a higher V, in the same word: [s]: v[e]l[s] "you see"; V Projection [e]l[s] "s/he is"

The projection cases are predictions of the algorithm. Each combinatorial selection may be relative to a domain. Higher and lower combinations therefore do not need to be relative to the same domain. Thus the interpretation of [h] in (ii2) requires a lexical and a

postlexical domain: the higher vowel cannot be in a different word.: *eʃa] ++[h]++[p]ara ti "this+fem is for you" eʃa][e][h][p]ara ti.

4. The process of stressed diphthongisation (García-Bellido, 1986) is a particular case of (14f.i). When an accent is tonally prominent (García-Bellido, 1997b) the algorithm (14f) requires the lower V [e] to be in the same word (14 fi.) and the higher X to be also in the same word (14f.i): laṡ++ '[j]j [e] rbas "the herbs".

5. I will assume throughout that a category E, which is timeless, connects together two segments which are not connected by a middle category. Thus a sequence of two vowels (7b) or a sequence of two consonants (7d) or a VC sequence as in (7a) connect with each other through a EP whose head is binuclear connecting VP and VP, CP and GP or YP and GP.

REFERENCES

- Baker, M. (1988) *Incorporation: A theory of grammatical function changing*. Chicago: University of Chicago Press.
- Bird, S. (1995) *Computational Phonology. A constraint-based approach*. Cambridge: University Press.
- Breen, G. and R. Pensalfini (1999) "Arernte: A language with No Syllable Onsets", *Linguistic Inquiry* 30.1, 1-25.
- Canfield Lincoln, D. (1988) *El español de América*. Barcelona: Editorial Crítica.
- Capland, D. et al. (1999) "Language and communication". In *Fundamental neuroscience*. Zigmund M et al. (eds). Academic Press.
- Cole, J. (1995) "The cycle in Phonology". In *The handbook of Phonological Theory*. Goldsmith J. (ed). Oxford: Blackwells.
- Costa, A. and A. Caramazza (1999) "Is lexical selection in bilingual speech production language specific? Further evidence from Spanish-English and English-Spanish bilinguals". *Bilingualism: Language and cognition* 2.3, 231-244.
- Chomsky, N. (1981) *Lectures on Government and Binding*. Dordrecht: Foris.
- Chomsky, N. (1995) *The Minimalist Program*. Cambridge, Mass.: MIT Press.
- Dresher, B.E. (1999) "Charting the learning Path: Cues to Parameter Setting", *Linguistic Inquiry* 30.1, 27-67.
- García-Bellido, P. (1979) "Trilled vs Flapped /r/: some remarks on the syllable structure of Spanish", *Cahiers Linguistiques d'Ottawa. Proceedings of the X North East Linguistics Society* 9, 109-125. University of Ottawa, Canada.

- García-Bellido, P. (1986) "Lexical diphthongisation and High-mid alternations in Spanish", *Linguistic Analysis* 16, 61-92.
- García-Bellido, P. (1989) "Aspectos recientes de la fonología autosegmental. Las palatales en español". In C. Martín Vide Ed. *Actas del IV Congreso de Lenguajes Naturales y Lenguajes Formales*. 4.1:514-27, Barcelona: Universitat de Barcelona.
- García-Bellido, P. (1996) "On the unification of syntax and phonology". Paper presented at the Phonology of the World's languages Symposium (Pezenas, France).
- García-Bellido, P. (1997a) "Functional/lexical categories: the syllable in Spanish". Paper presented at HILP 3 Amsterdam.
- García-Bellido, P. (1997b) "The interface between inherent and structural prominence in Spanish". In Martínez-Gil and Morales-Front (eds). 469-514.
- García-Bellido, P. (1999) Local movement and the syntax of Spanish sounds. *Oxford University Working Papers in Linguistics, Philology and Phonetics*. 4: 1-17.
- Green, D.W. (1998) "Mental control of the bilingual lexico-semantic system", *Bilingualism: Language and Cognition* 1,67-81.
- Goldsmith, J. (1976) *Autosegmental Phonology*. Doctoral dissertation, MIT. New York, Garland Press, 1979.
- Hale, K. and S. J. Keyser (1993) "On argument structure and the Lexical expression of syntactic relations". In *The view from Building 20*. Hale, J. and J. Keyser (eds). Cambridge, Mass.: MIT Press.
- Halle, M. (1995) "Feature geometry and feature spreading", *Linguistic Inquiry* 26:1-46.
- Harris, J. (1980) "Palatal- \emptyset alternations in Spanish". In F.H. Nuessel, Jr. (ed.) *Contemporary studies in Romance languages*. Bloomington, Indiana: Indiana University Linguistics Club.108-30.
- Harris, J. (1983) *Syllable structure and stress in Spanish. A nonlinear analysis*. Monograph 8. Cambridge, Mass.: MIT Press.
- Harris, J. (1984) "Autosegmental Phonology, Lexical Phonology, and Spanish Nasals". In M. Aronoff and R.T. Oehrle (eds). *Language Sound Structure*. Cambridge, Mass.: MIT Press, 67-82.
- Harris, J. and E. M. Kaisse (1999) "Palatals in Argentinian Spanish", *Phonology* 16:2: 117-190.
- Hayes, B. (1986) "Inalterability in CV Phonology", *Language* 62: 321-51.
- Hayes, B. (1995) *Metrical Stress theory. Principles and case studies*. Chicago: The University of Chicago Press.
- Hayes, B. (1989) "Compensatory lengthening in moraic phonology", *Linguistic Inquiry* 20:253-306.

- Hualde, J. I. (1992) "On Spanish syllabification". In Campos, M. and F. Martínez-Gil (eds). *Current studies in Spanish Linguistics*. Washington D.C.: Georgetown University Press. 475-93.
- Huang, C. T. J. (1982) *Logical Relations in Chinese and the Theory of Grammar*. Doctoral dissertation. Cambridge, Mass.: MIT.
- Itô, J. (1989) "A prosodic Theory of Epenthesis", *Natural language and Linguistic Theory*. 7:217-59.
- Kayne, R. (1984) *Connectedness and binary branching*. Dordrecht: Foris.
- Kent, R. D. and G. Miolo (1995) "Phonetic abilities in the first year of life." *The handbook of Child language*. Fletcher P. and B. MacWhinney (eds). Oxford: Blackwells.
- Khan, D. (1976) *Syllable-based Generalizations in English Phonology*. Doctoral Dissertation. Cambridge, Mass.: MIT.
- Levin, J. (1985) *A metrical theory of syllabicity*. Doctoral dissertation. Cambridge, Mass.: MIT.
- Macken, M. (1993) "Developmental changes in the acquisition of Phonology." *Developmental neurocognition: Speech and face processing in the first year of life*. Dordrecht: Kluwer.
- Manzinni, M.-R. (1992) *Locality: A theory and some of its empirical consequences*. Cambridge, Mass.: MIT Press.
- Martínez-Gil, F. and A. Morales-Front (eds) (1997) *Issues in the phonology and morphology of the major Iberian languages*. Washington: Georgetown University Press.
- Mascaró, J. (1984) "Continuant spreading in Basque, Catalan, and Spanish." In M Aronoff and R.T. Oehrle (eds). *Language Sound Structure*. Cambridge, Mass.: MIT Press, 287-298.
- McCarthy J. (1979) *Formal problems in Semitic Phonology and Morphology*. Doctoral dissertation Cambridge, Mass.: MIT.
- Menéndez Pidal, R. (1968) *Manual de gramática histórica española*. Madrid, Espasa Calpe.
- Menn L. and C. Stoel-Gammon (1995) "Phonological development." *The handbook of Child language*. Fletcher P. and B. MacWhinney (eds). Oxford: Blackwells.
- Nespor, M. and I. Vogel (1986) *Prosodic Phonology*. Dordrecht, Foris.
- Penny, R. (1991) *A history of the Spanish language*. Cambridge: University Press.
- Pinker, S. (1994) *The language Instinct. The new science of language and mind*. London: The Penguin Press.
- Poulisse, N. (1997) "Language production in bilinguals". In A.M.B.de Groot and J.F.Kroll (eds). *Tutorials in bilingualism: Psycholinguistic perspectives* Mahwah, NJ: Lawrence Erlbaum Associates. 201-224.

- Priestly, T. M. S. (1977) "One idiosyncratic strategy in the acquisition of phonology", *Journal of Child Language*, 4:45-66.
- Quilis, A. (1981) *Fonética acústica de la lengua española*. Madrid: Gredos.
- Rischel, J. (1974) *Topics in Greenlandic Phonology*. Copenhagen.
- Rizzi, L. (1990) *Relativized Minimality*. Cambridge, Mass.: MIT Press.
- Schein, B. and D. Steriade (1986) "On geminates", *Linguistic Inquiry* 17. 4, 691-744.
- Selkirk, E. (1984) *Phonology and Syntax: The relationship between sound and structure*. Cambridge, Mass.: MIT Press.
- Smith N.S.H. (1999) "A preliminary account of some aspects of Leurbost Gaelic Syllable structure." In H. van der Hulst and N. Ritter (eds) (1999) *The syllable: views and facts*. Berlin: Mouton de Gruyter, 557-630.
- Smith N.S.H. (2000) *Evidence for recursive syllable structures in Aluku and Sranan*. Ms Dept. of Theoretical Linguistics. University of Amsterdam.
- Van der Hulst, H. and J. van der Weijer (1995) "Vowel harmony". In *Handbook of Phonology* Goldsmith J. A. (ed). Oxford: Blackwells.
- Zamora Vicente, V. (1985) *Dialectología española*. Madrid: Gredos. 2nd Edition.